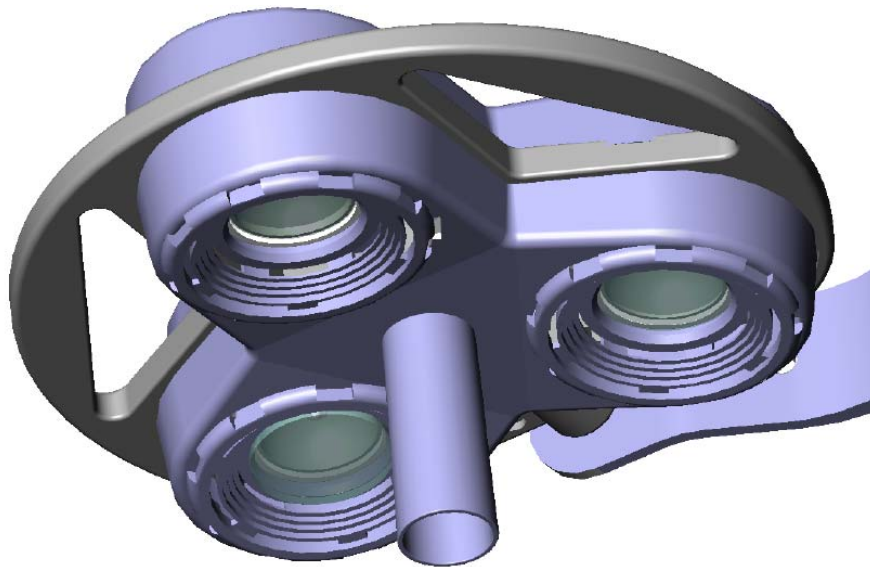


SUNNEX MEDICALIGHT<sup>®</sup>

INSTALLATION & OPERATING MANUAL

# Celestial Star



**CS2050M (Mobile)**

**CS2050W (Wall)**

**CS2050C (Ceiling)**

**CS2050D (Dual)**

**[WWW.SUNNEXMEDICAL.COM](http://WWW.SUNNEXMEDICAL.COM)**

 **sunnex<sup>®</sup>**

*Dear Customer:*

We appreciate that you have chosen to purchase a Sunnex Medical product and believe that it will fulfill your expectations. Sunnex takes great pride in our products which have been designed and manufactured in accordance with our strict ISO 9001 certified quality system, UL and CE electrical standards and, if applicable, the United States Food and Drug Administration's regulations. You will find Sunnex brand products to be reliable, durable, and an exceptional value providing innovation while maintaining a low overall lifetime cost.

We try our utmost to focus on our customers needs. Our sales and customer service staff will assist you with any questions you might have regarding your new Sunnex product - the functionality, installation or other concerns. Sunnex's network of business partners - National and Regional distributors may also be called upon to provide excellent advice and additional sales support.

Again, I thank you for purchasing Sunnex products and I believe it will serve you well.

Anders Utter  
President, Sunnex, Inc.

# CONTENTS

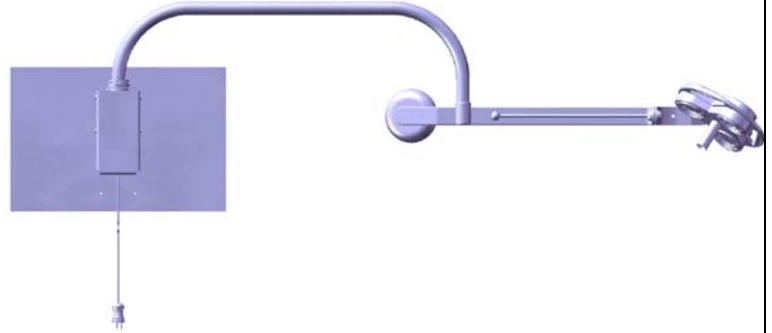
<b>1. Introduction .....</b>	<b>3</b>
1.1 Contents and Packaging	
1.2 About the Light	
<b>2. Technical Description .....</b>	<b>5</b>
2.1 Technical Data	
2.2 Symbols	
2.3 Main Components and Dimensions	
<b>3. Customer Responsibilities .....</b>	<b>7</b>
<b>4. Pre-wiring Instructions.....</b>	<b>8</b>
4.1 Standard Receptacle Installations	
4.2 Hard-wire to Junction Box	
<b>5. Installation Instructions .....</b>	<b>8</b>
Ceiling Light.....	<b>8</b>
5.1 Pre-installation Instructions	
5.2 Installation Instructions	
Ceiling Dual Light .....	<b>15</b>
5.3 Pre-installation Instructions	
5.4 Installation Instructions	
Wall Light .....	<b>16</b>
5.5 Installation Instructions	
Mobile Light .....	<b>18</b>
5.6 Installation Instructions	
<b>6. Operating Instructions.....</b>	<b>19</b>
<b>7. Maintenance .....</b>	<b>20</b>
7.1 Cleaning and Disinfection	
7.2 Handle Autoclaving	
7.3 Bulb Replacement	
7.4 Fuse Replacement	
<b>8. Warranty .....</b>	<b>23</b>
<b>9. Troubleshooting .....</b>	<b>26</b>
<b>10. Appendix .....</b>	<b>27</b>

# 1. Introduction

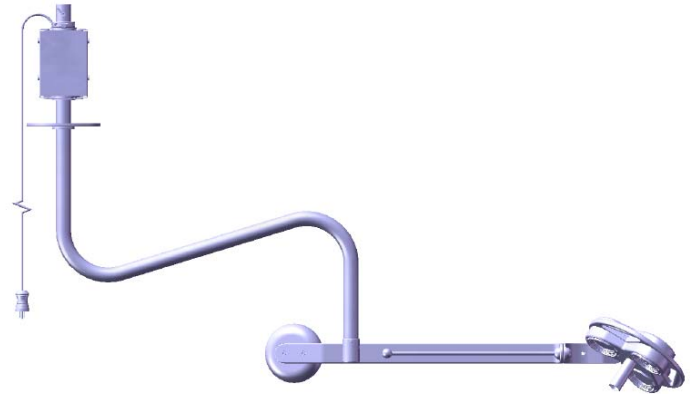
## 1.1 Contents and Packaging



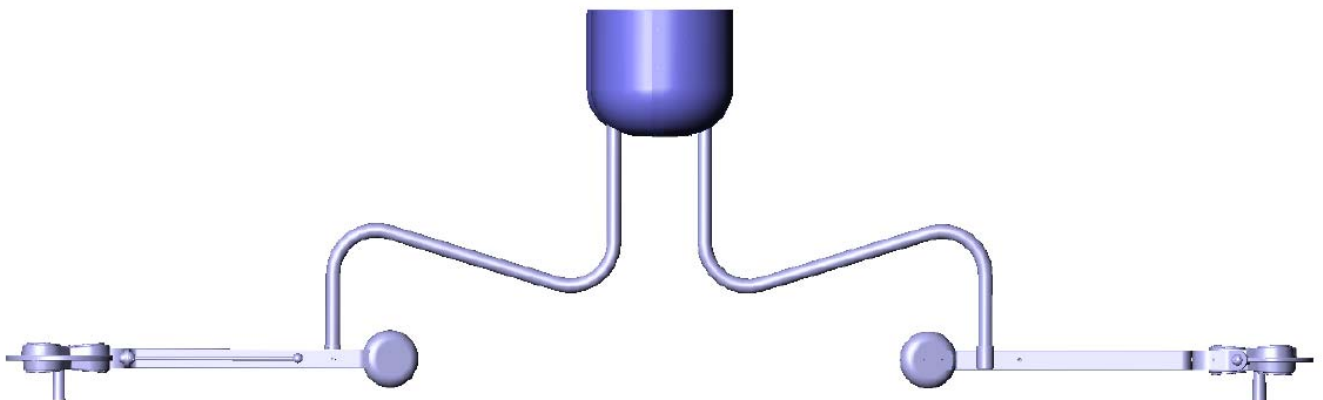
**Mobile**



**Wall**



**Ceiling**



**Ceiling Dual**

### Packaging Checklist

CONTENTS	CEILING	DUAL CEILING	WALL	MOBILE
BALANCE ARM ASSEMBLY	1	2	1	1
CEILING ARM & TRANSFORMER ASSEMBLY	1	2		
BOX CONTAINING - ONE (1) SET OF DOME COVERS (LEFT & RIGHT) - ONE (1) SEISMIC BRACKET DUAL		1		
U ARM & TRANSFORMER ASSEMBLY			1	
WALL BOARD			1	
VERTICAL POLE ARM & TRANSFORMER ASSEMBLY				1
CASTER BASE WITH WHEELS				1
COUNTER BALANCE	1	2	1	1
ACCESSORY BAG TO INCLUDE FOLLOWING:				
- STERILIZABLE HANDLE	1	2	1	1
- INSTRUCTION MANUAL & WARRANTY CARD	1	2	1	1
- FLAT HEAD SCREWS (1/4-20 X 1/2")	2	4	2	2
- PAN HEAD SCREWS (8-32 X 1/2")	3	6	3	3
- ALLEN WRENCH – 5/32	1	2	1	1
- PAN HEAD PLASTIC SCREWS (1/4-20 X 1/2")	4	8	4	
- HEX BOLT (1/4-20 X 3/4")			4	
- ALLEN WRENCH – 5/16		1		
- HEX BOLTS (3/8-24 X 3/4")		4		
- HEX NUTS (3/8-24 X 1/2")		4		
- ALLEN WRENCH – 1/8	1	1	1	1
- CEILING COVER (AESTHETIC)	1	2		

*\*Carefully check the contents of the shipment. Report shortages and/or errors, to Sunnex or your dealer's customer service department, within five (5) working days. The carton and its inserts should be kept for inspection by the transportation company if you see damage in the packages received.*

#### 1.2 About the Light

You will find your Celestial Star light, with its many features, ideal for a myriad of clinical applications, minor surgical procedures and gross examination. It provides excellent illumination with a minimum of shadows for use in emergency departments, trauma rooms, and other critical care areas.

#### **Surgical Light Features**

- High Light Output ... up to 60,000 Lux
- High Color Temperature, 3300 Degree Kelvin
- Patented Lamp Shade reduces heat output
- Unparalleled Flexibility with Extensive Reach and Range of Motion
- Drift Free Balance Arm Design
- Quick & Easy Bulb Replacement
- Removable Sterilizable Handle





This manual will assist you in assembling your light, introduce some of its most important and prominent features, and provide suggestions for its care. The light is intended for use in medical specialty environments where illumination is required for various medical examinations and procedures. The light must be operated with the safety of the user and patient in mind. Please read this manual carefully and any other instructions prior installing the equipment.

## 2. Technical Description

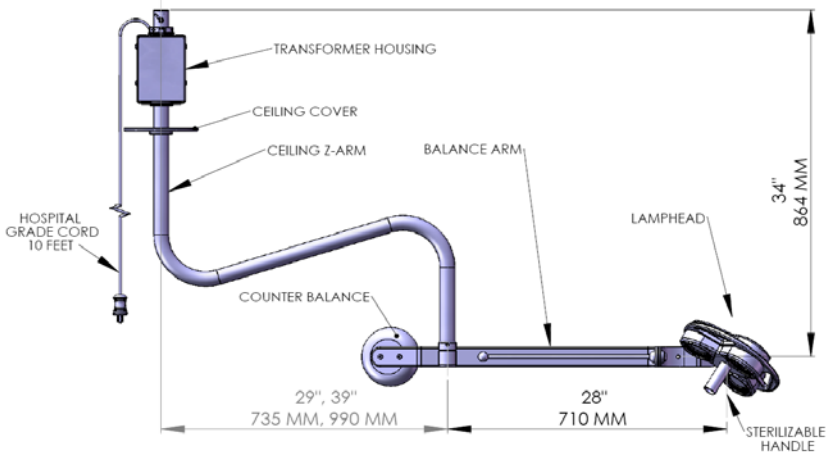
### 2.1 Technical Data

SPECIFICATION	VALUE & CONDITION
Power supply	120V - 60Hz and 230V - 50Hz-60Hz (+/-10%)
Fuse	<b>120V</b> :Sunnex part# 18565 (2 AMP, 250V, 1/4" X 1-1/4", SLOW BLOW) <b>230V</b> : Sunnex part# 18641 (1.25 AMP, 250V, 5mm X 20mm, SLOW BLOW)
Nominal Effect	120Vac, 60Hz, 3 X 35W - 1.5A 230Vac, 50Hz, 3 X 35W - 1.0A
Light Source	Halogen bulb - Dichroic 3 X 12V/35W/10°
Bulb Life	4,000 hours
Light Intensity	46,000 Lux at 1 Meter
Color Temperature	3,300 Degree Kelvin
Color Rendering Index	96
Total Irradiance	116W/m <sup>2</sup>
Medical Standard	Class II
Total Weight	Ceiling – 56 lbs (25 Kg) Ceiling Dual - 130 lbs (59 Kg) (including dual seismic bracket) Wall - 64 lbs (29 Kg) (including wall board) Mobile - 40 lbs (18 Kg)
Moment	(One 29" [74cm] long ceiling arm) = 50 lbs X 57 inches = 2,850 lbs-inches (322 Nm) (One 39" [100cm] long ceiling arm) = 50 lbs X 67 inches = 3,350 lbs-inches (379 Nm)
Mode of Operation	Continuous
Certifications	<b>ETL Listed:</b> CAN/CSA-C22.2 No. 601.1-M90 EN60601-1, UL60601-1, EN60601-2-41 UL60601-2-41, IEC 60601-1-2 (2001-09) 2nd edition (EN55011:1991, Group I Class B)

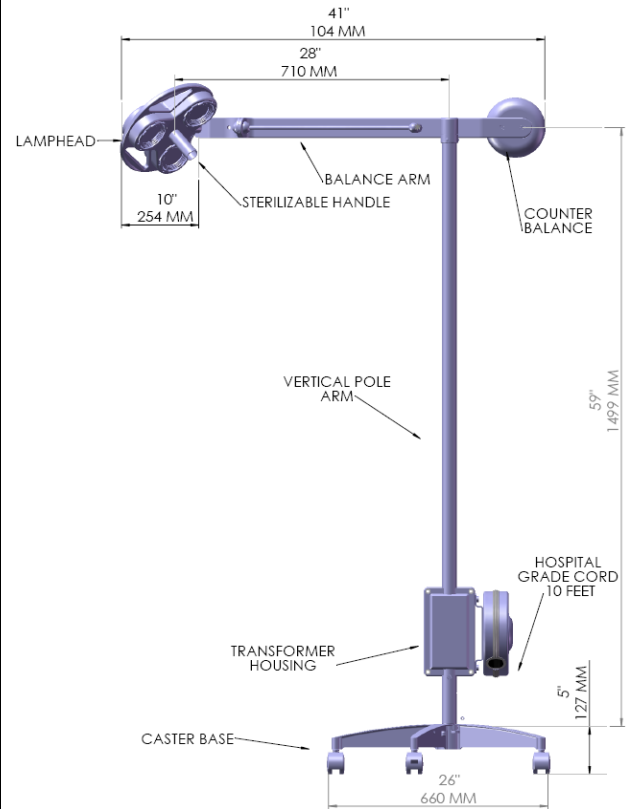
### 2.2 Symbols

			
<b>GROUND</b>	<b>SWITCH ON</b>	<b>SWITCH OFF</b>	<b>CAUTION</b>

### 2.3 Main Components and Dimensions

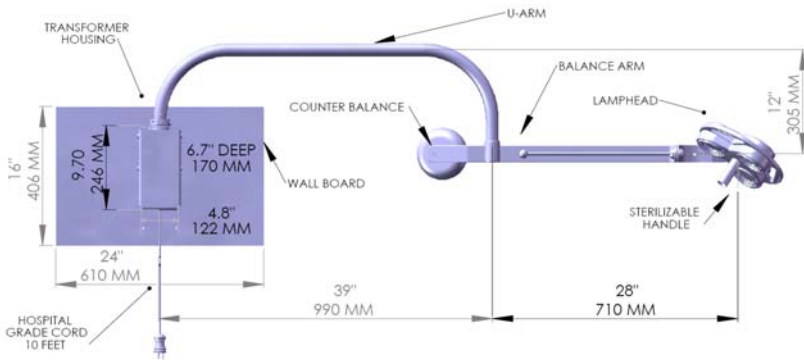


**Figure 1. Ceiling**



**Figure 3. Mobile (120V Model)**

**(230V Model does not come with cord reel, instead it has cord hooks)**



**Figure 2. Wall**

### 3. Customer Responsibilities

Sunnex lights are built to provide exceptional illumination and should impart you with years of reliable service. Please follow the list below of installation criteria to ensure proper steps are taken prior to the mounting of the fixture, and help ensure its appropriate use.

- ✓ Note down product's serial #
  - **Serial # is:** \_\_\_\_\_
- ✓ Carefully follow guidelines specified in this manual (refer to figures 8, 9 and 10)
- ✓ The contractor / installer has responsibility for the superstructure / mounting brackets strength and stability
- ✓ Check with State and Local compliance boards or engineering agencies to assure that all installation and use codes are followed

## 4. Pre-wiring Instructions

### 4.1 Standard Receptacle Installations

Standard models are designed to be used with standard hospital grade 3 prong grounded outlet (receptacle) boxes. No modification or pre-wire is required.

### 4.2 Hard-wire to Junction Box

The hard-wiring instructions apply to following models only:

1. CS2050C-HW (Ceiling, 120V)
2. CS2050W-HW (Wall, 120V)
3. CS2050CE-HW (Ceiling, 230V)
4. CS2050WE-HW (Wall, 230V)



**CAUTION: A LICENSED ELECTRICIAN MUST BE UTILIZED TO PERFORM HARD-WIRING INSTALLATIONS, NATIONAL ELECTRICAL CODE (NEC) MUST BE FOLLOWED DURING HARD-WIRING INSTALLATION.**

The lights mentioned above may be hard-wired with mains supply. During such hard-wiring, the following instructions must be used:

1. The light is supplied with a hard service cord (STOW 18/3, 600V,  $-35^{\circ}\text{C}$  to  $105^{\circ}\text{C}$ , 10 Amp per conductor @  $25^{\circ}\text{C}$ , approved as water resistant, oil resistant, outdoor use) suitable for ceiling hard-wiring applications. The cord has 3 conductors (Hot, Neutral and Ground). The earth and neutral conductors are labeled as follows:

EARTH	
NEUTRAL	N

2. This STOW cord runs through a hole in the transformer box. The outer diameter of the STOW cord is 0.378" (9.66mm). The hole in transformer box is 0.80" (20mm) for a metal conduit of (trade size 1/2 or metric designator 16). The conduit must be fixed to the transformer box with use of nut.
3. Connect the earth conductor with earthing of the facility, neutral conductor with neutral of mains supply and hot conductor with hot terminal of mains supply.
4. Use proper wire nuts of appropriate electrical rating considering the STOW cord specifications and electrical rating of the light.

## 5. Installation Instructions

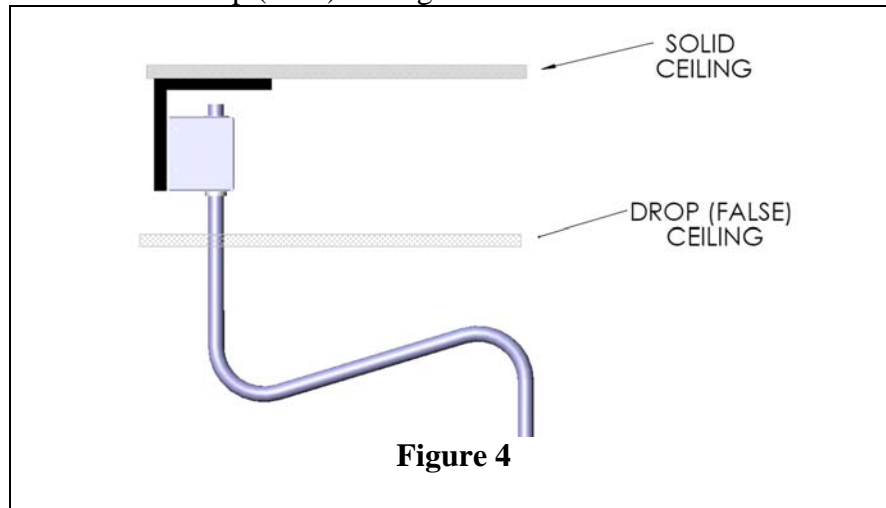
### Ceiling Light

#### 5.1 Pre-installation Instructions

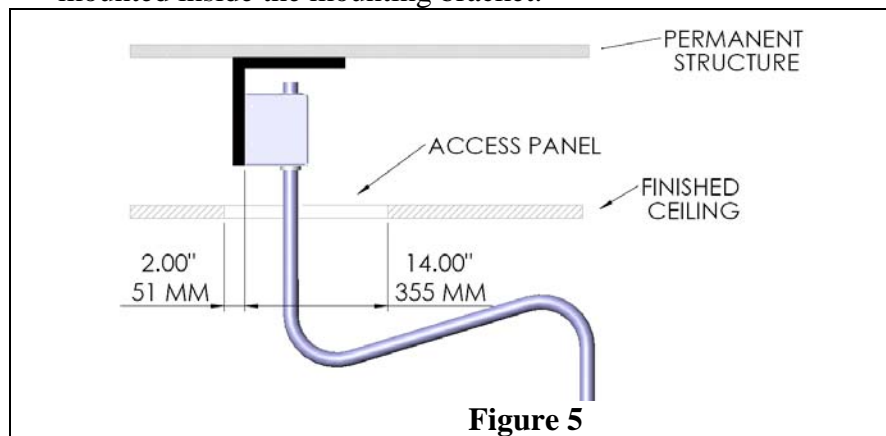
Please follow the directions for assembly carefully, as failure to do so may result in the voiding of the lights warranty. \* Note - any modification to the physical or mechanical structure of the lamp will most likely be cause to void any UL, CE or other electrical listing which this product may carry.

Refer to **Figures 8, 9 & 10** and **Table 1** for mounting heights and appendix A for hole pattern of the transformer housing and optional brackets & plates.

1. NEVER attempt to affix a ceiling light directly to a drop (false) ceiling, as many are not designed to withstand the weight requirements of the lighting systems, and may result in damage to the ceiling, the lighting unit or both. Additionally this may present a situation where failure may present a hazard to persons, resulting in injury.
2. The transformer housing should be mounted against a permanent member just above the drop (false) ceiling.



3. If during construction or remodeling, the ceiling surface is to be finished, it is recommended that the installation of the light be accomplished first, leaving a small access panel to facilitate access to the transformer housing and the safety fuses mounted inside the mounting bracket.



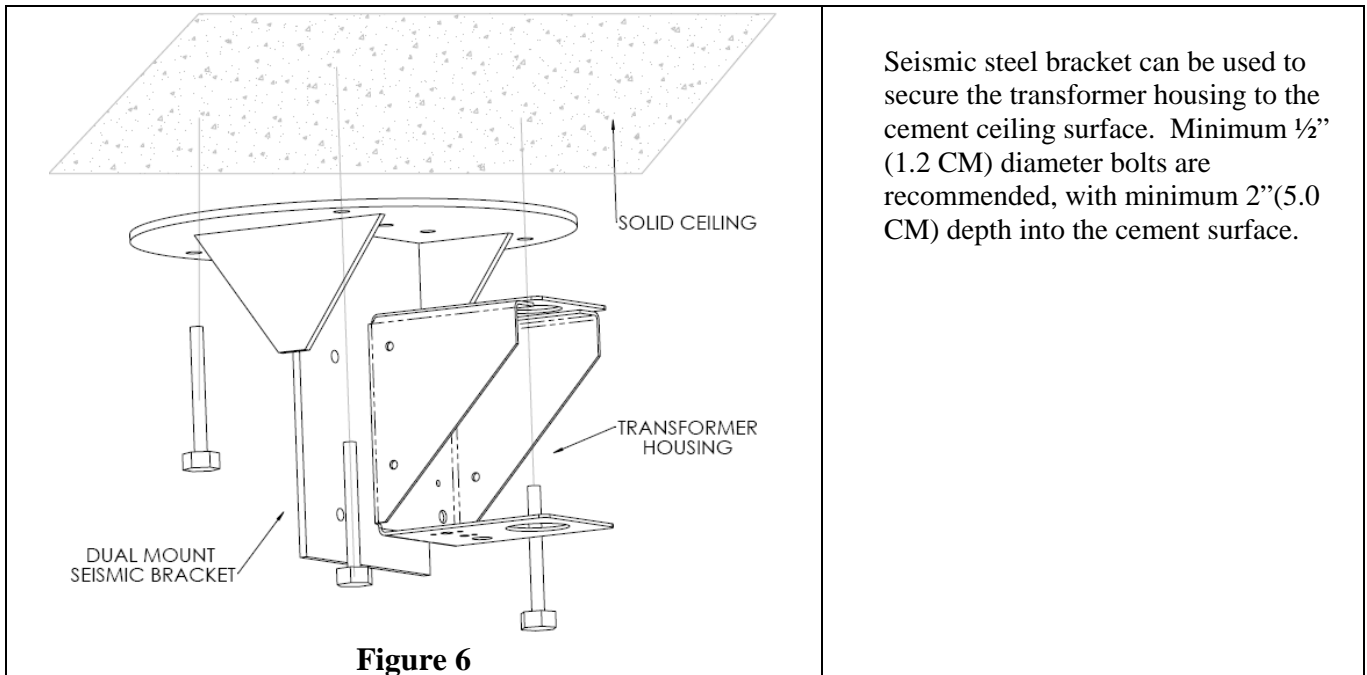
4. Installations in which there is a distance of over 24 inches between the hard ceiling surface and the drop (false) ceiling surface, often requires construction of an additional support structure.
5. Weight:

One ceiling light (29" horizontal arm)	56 Lbs (25 Kg)
One ceiling light (39" horizontal arm)	58 Lbs (26 Kg)
Dual ceiling lights (29" horizontal arm) plus dual seismic bracket	130 Lbs (59 Kg)

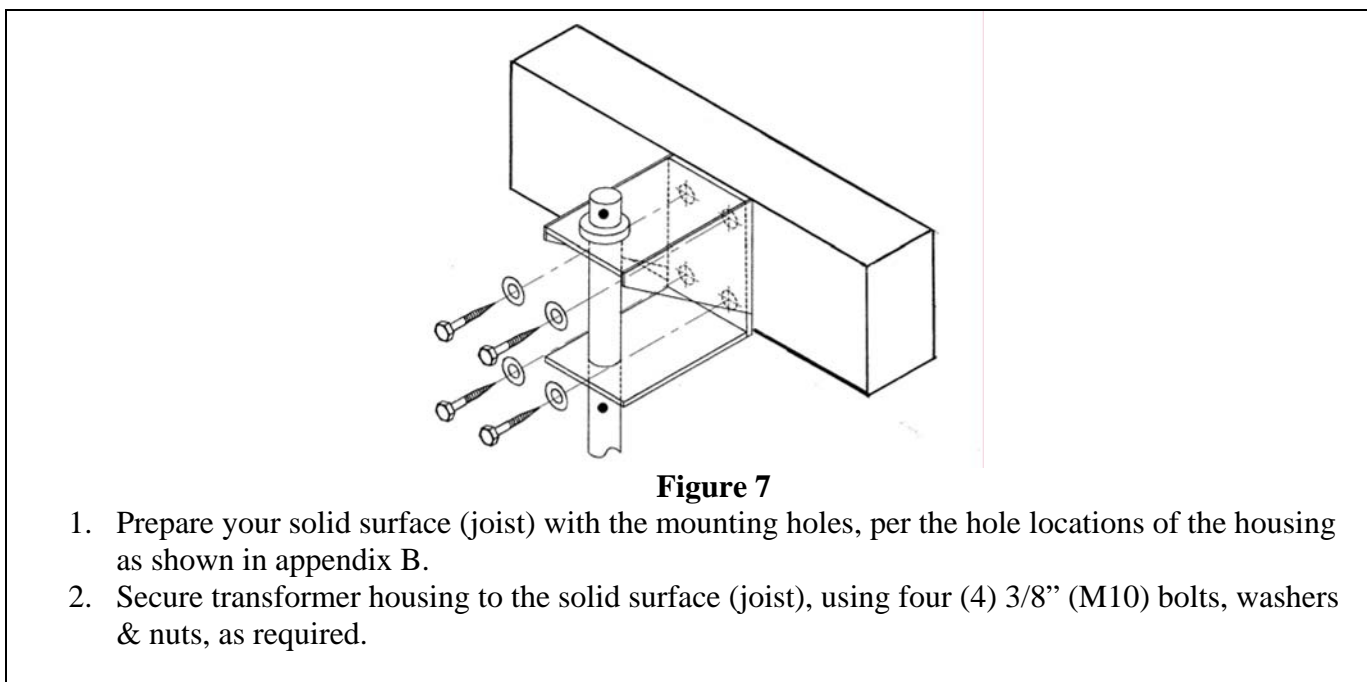
6. The contractor assumes the ultimate responsibility for the stability and strength of the final mounted fixture.

## MOUNTING TO A HORIZONTAL SURFACE

An L-bracket can be used to secure the transformer housing to horizontal plane above the drop (false) ceiling. Please refer to the dimensions of the optional bracket in appendix A.



## MOUNTING TO VERTICAL SURFACE



**Table 1 Guideline for ceiling style mount**

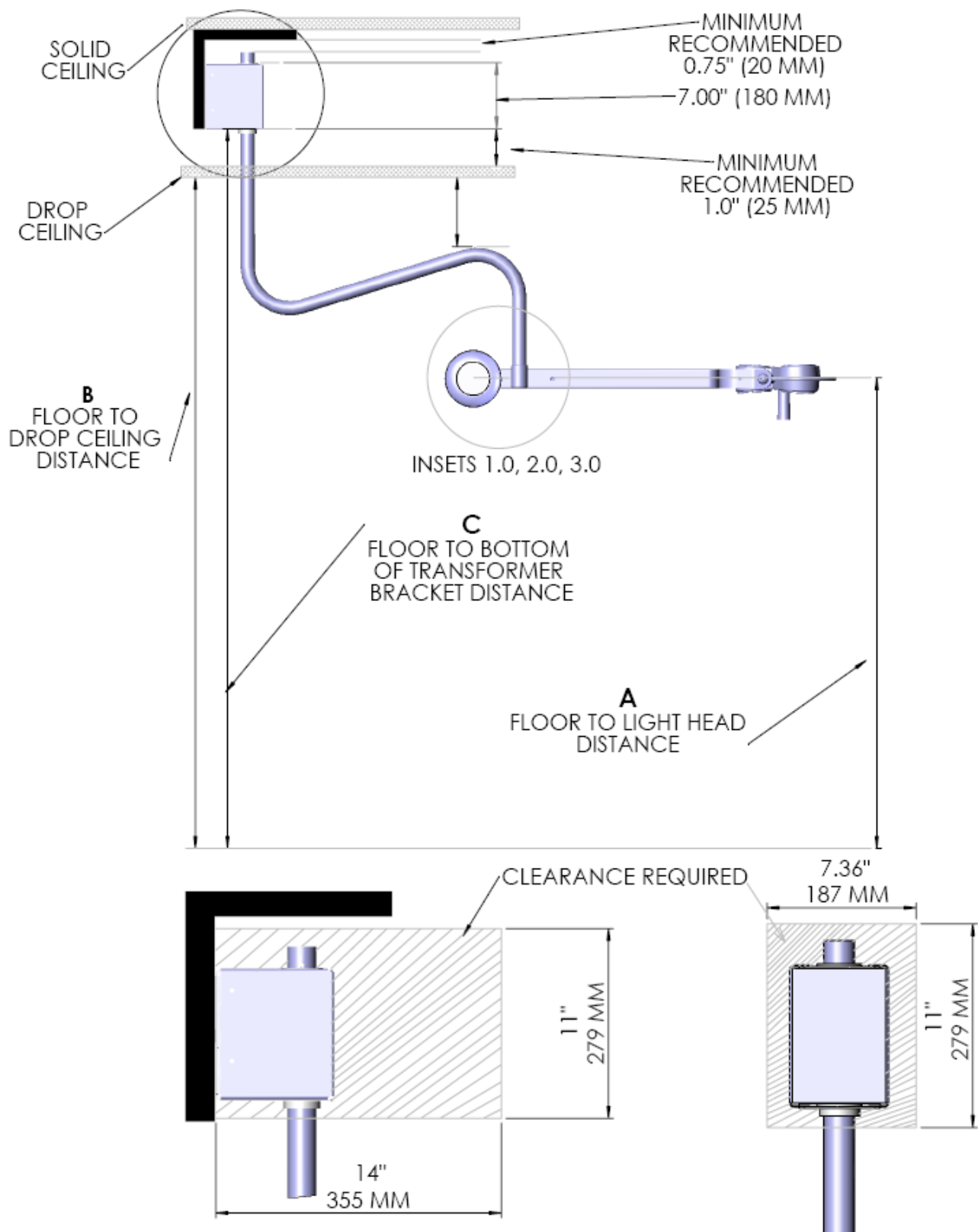
(Refers to Figures 8, 9 & 10)

**CEILING LIGHT MOUNTING INSTRUCTIONS  
WITH STANDARD EXTENSION Z-ARM**

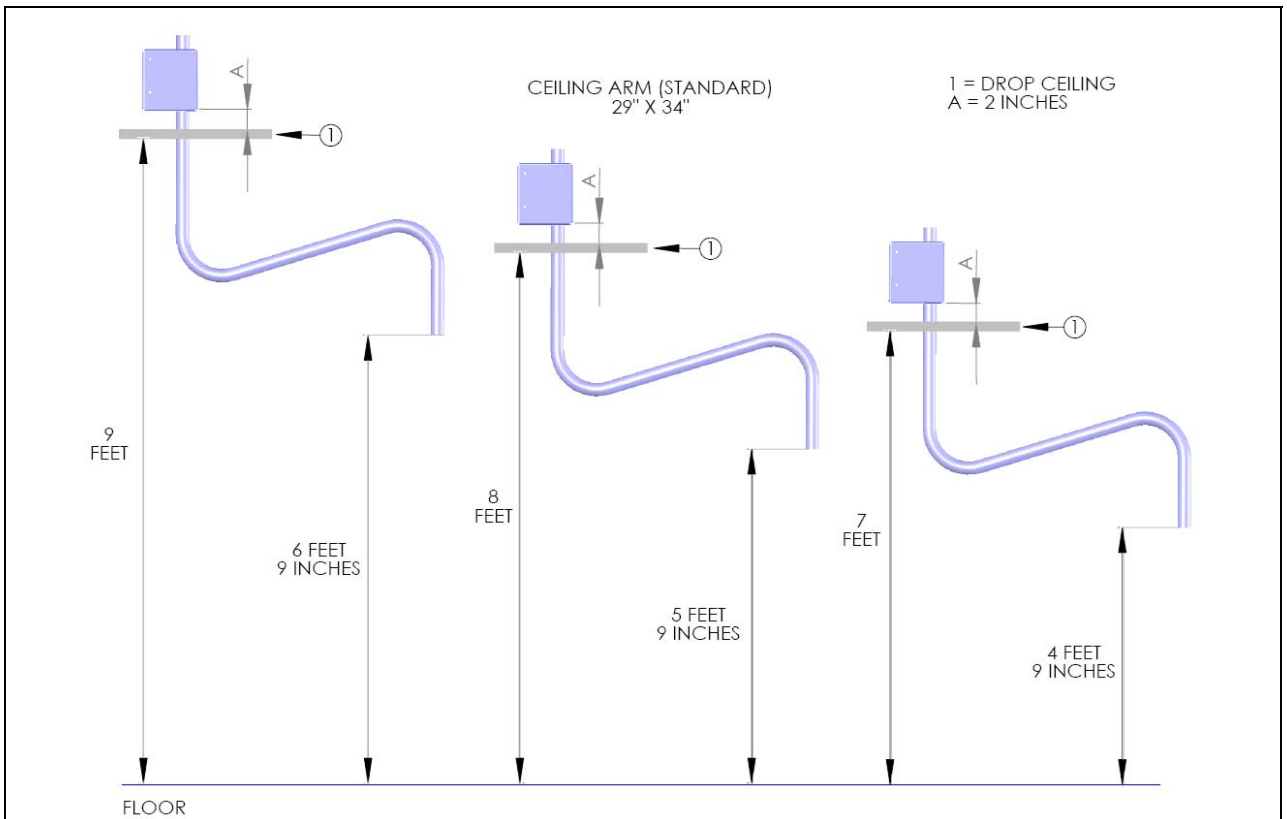
<b>TO ACHIEVE FLOOR TO LIGHT DISTANCE OF “A”</b>	<b>IF DROP CEILING IS “B”</b>	<b>MOUNT BOTTOM OF TRANSFORMER BRACKET FROM FLOOR AT “C”</b>
<b>75 INCHES (1905 mm)</b>	<b>7.5 FEET (2280 mm)</b>	<b>101.5 INCHES (2578 mm)</b>
<b>75 INCHES (1905 mm)</b>	<b>8.0 FEET (2440 mm)</b>	<b>101.5 INCHES (2578 mm)</b>
<b>80 INCHES (2032 mm)</b>	<b>8.0 FEET (2440 mm)</b>	<b>106.5 INCHES (2705 mm)</b>
<b>80 INCHES (2032 mm)</b>	<b>9.0 FEET (2740 mm)</b>	<b>112.5 INCHES (2857 mm)</b>

**CEILING LIGHT MOUNTING INSTRUCTIONS  
WITH EXTRA-HIGH EXTENSION Z-ARM**

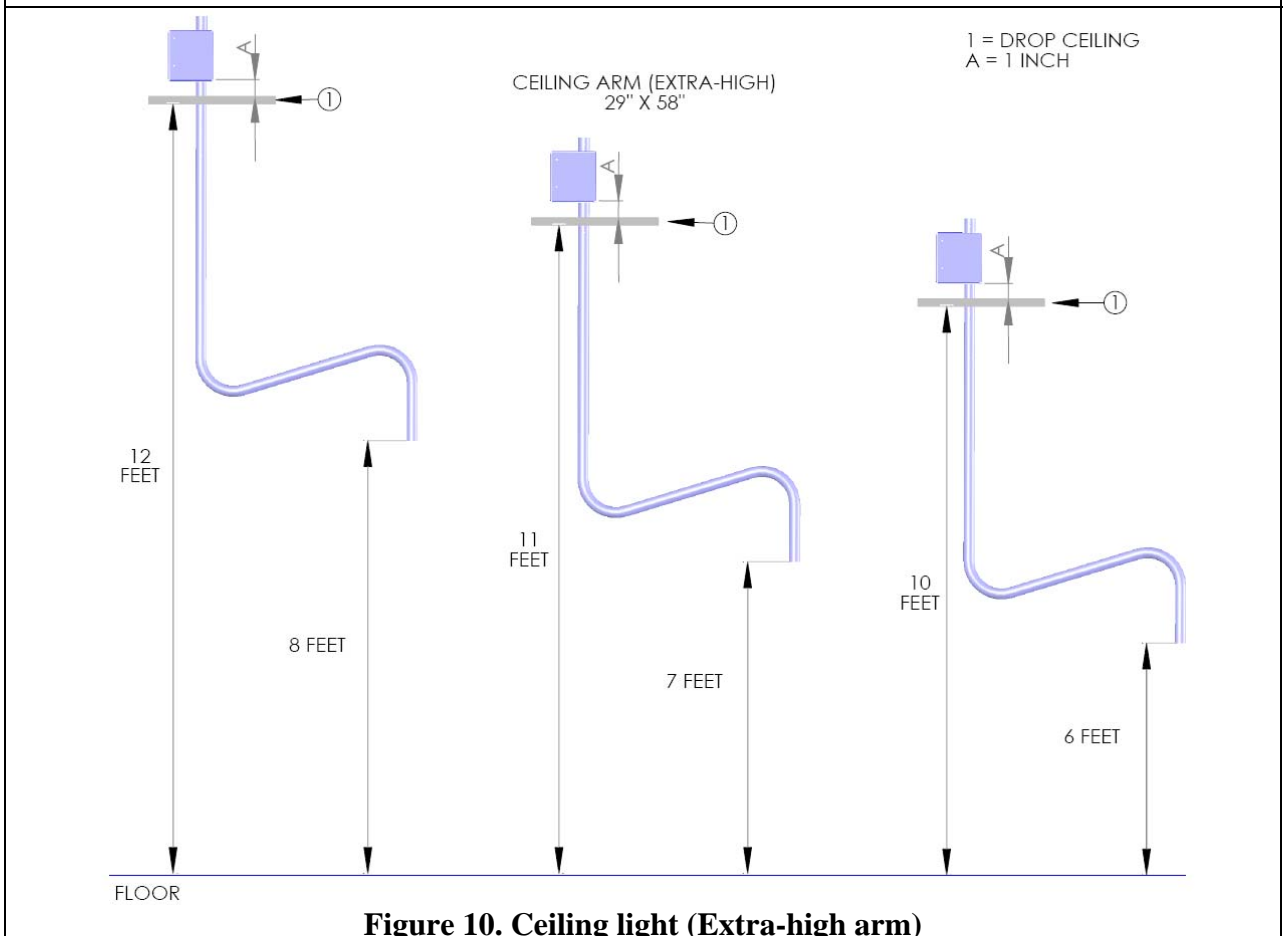
<b>TO ACHIEVE FLOOR TO LIGHT DISTANCE OF “A”</b>	<b>IF DROP CEILING IS “B”</b>	<b>MOUNT BOTTOM OF TRANSFORMER BRACKET FROM FLOOR AT “C”</b>
<b>72 INCHES (1828 mm)</b>	<b>10 FEET (2280 mm)</b>	<b>121 INCHES (3073 mm)</b>
<b>84 INCHES (2159 mm)</b>	<b>11 FEET (3350 mm)</b>	<b>133 INCHES (3378 mm)</b>
<b>96 INCHES (2438 mm)</b>	<b>12 FEET (3650 mm)</b>	<b>145 INCHES (3686 mm)</b>



**Figure 8. General mounting (shown with an L-bracket)**



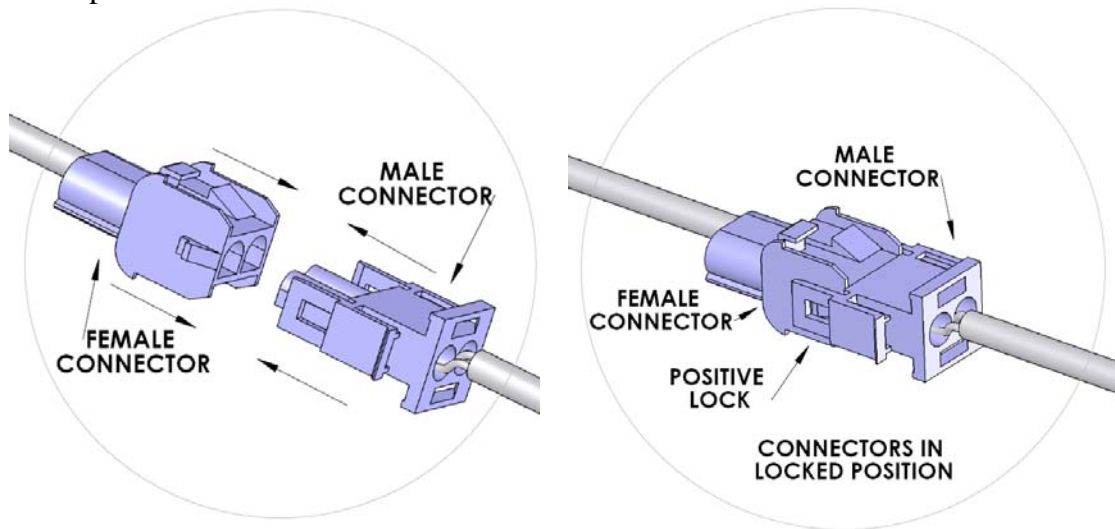
**Figure 9. Ceiling light (Standard arm)**



**Figure 10. Ceiling light (Extra-high arm)**

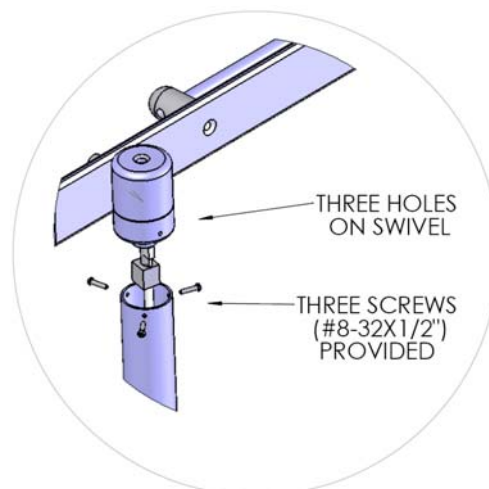
## 5.2 Installation Instructions

1. Slide transformer housing covers off of transformer brackets and set aside for future installation.
2. Follow Table 1 and Figures 8, 9 & 10 to determine the location of installation.
3. Fasten the transformer housing to the desired location using four (4) 3/8" or M10 bolts (not provided). The type of bolt will be dependent on your installation. These bolts may need to be either lag or machine bolts. Minimum lag bolt length is 2-1/4" or 60mm. Verify that the transformer housing is level. If not, arm will drift.
4. Position and install transformer housing cover on mounting bracket. Secure with plastic screws (4) provided.
5. Connect the male connector with the female connector on swivel joint of the balance arm. Connectors can be installed only one way. Ensure that connectors make a **"CLICK"** sound for a positive lock.



Inset 1.0 (Figure 8)

6. Line up the holes on arm with the holes on the swivel joint on the balance arm. Use the (3) pan head screws (#8-32X1/2") provided to secure the connection.



Inset 2.0 (Figure 8)

7. Fix the round counter weight to other end of the lamp head balance arm. There are two

counter sunk holes on this end of the balance arm. Position the counter weight on the opposite side of the counter sunk holes on the balance arm. Set the (2) flat head screws (1/4-20" X 1/2") supplied hex screws in the counter sunk holes and tighten them down using provided (5/32") Allen wrench.



Inset 3.0 (Figure 8)

8. Insert the sterilizable handle onto the mounting screw in the center of the lamp head and rotate clockwise to tighten.



9. Plug the hospital grade plug into the outlet. The light is ready for use.

### 5.3 Pre-Installation Instructions (Ceiling Dual Light)

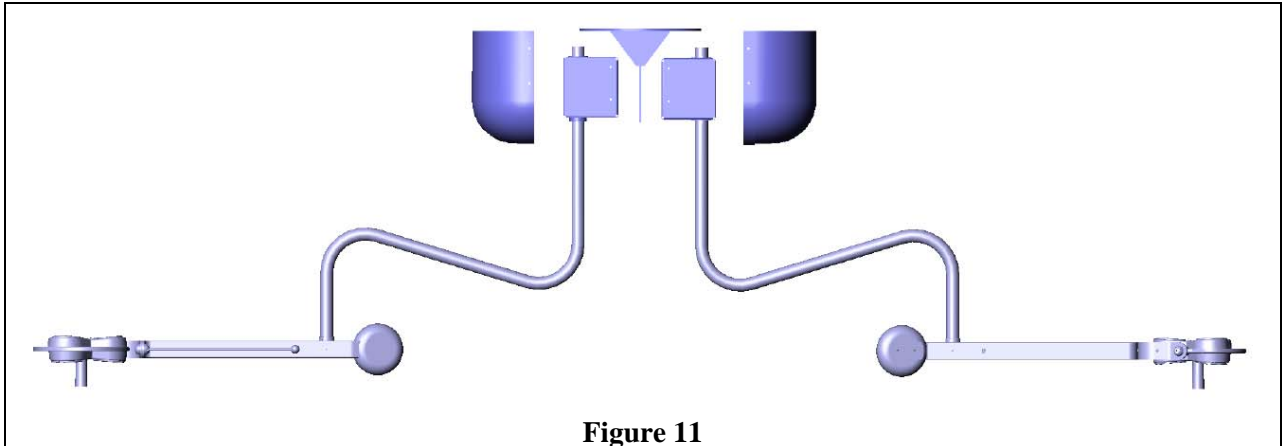
1. The dual mounted light comprises of two identical single ceiling mounted lights combined with the use of a dual seismic ceiling bracket.
2. In order to utilize the provided aesthetic dome covers, the dual mount seismic bracket must be used. These installations are predominantly below the false ceiling. If installing the dual light above a drop ceiling, it is likely the bracket cover (dome) will not be required as the bracket will not be visible to the user. Alternatively, the flat, plastic ceiling covers (provided

with each light) can then be used to cover the hole in the drop ceiling created for the extension arms.

3. The dimensions and recommended installation heights are identical to the single ceiling arm.

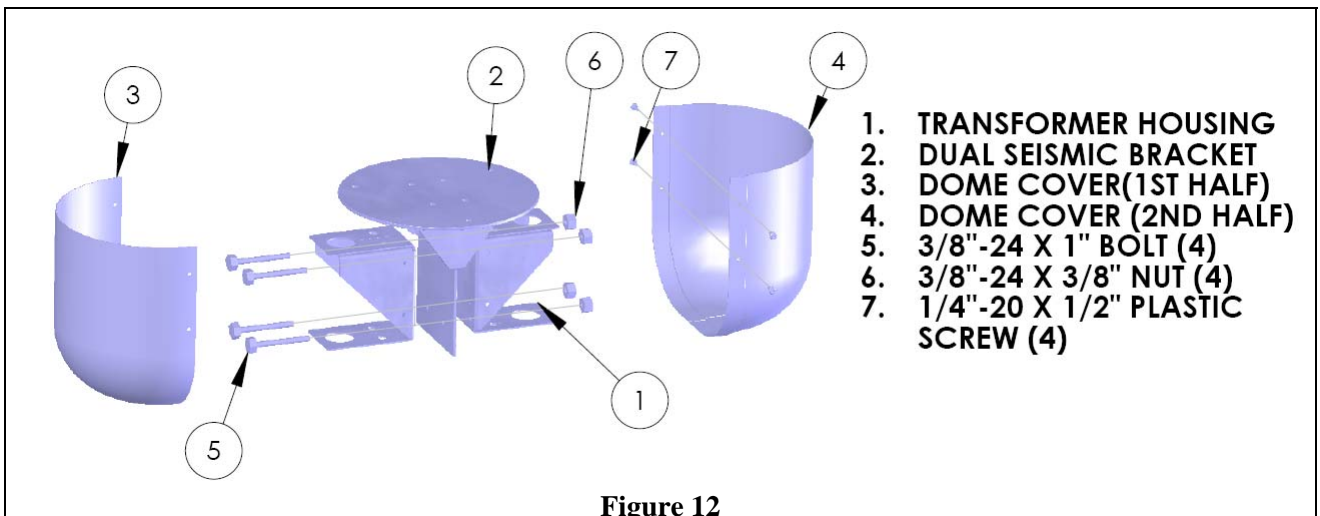
#### 5.4 Installation Instructions (Ceiling Dual Light)

1. Follow instructions in sections 5.1 and 5.2 to complete installation of lights to ceiling.



**Figure 11**

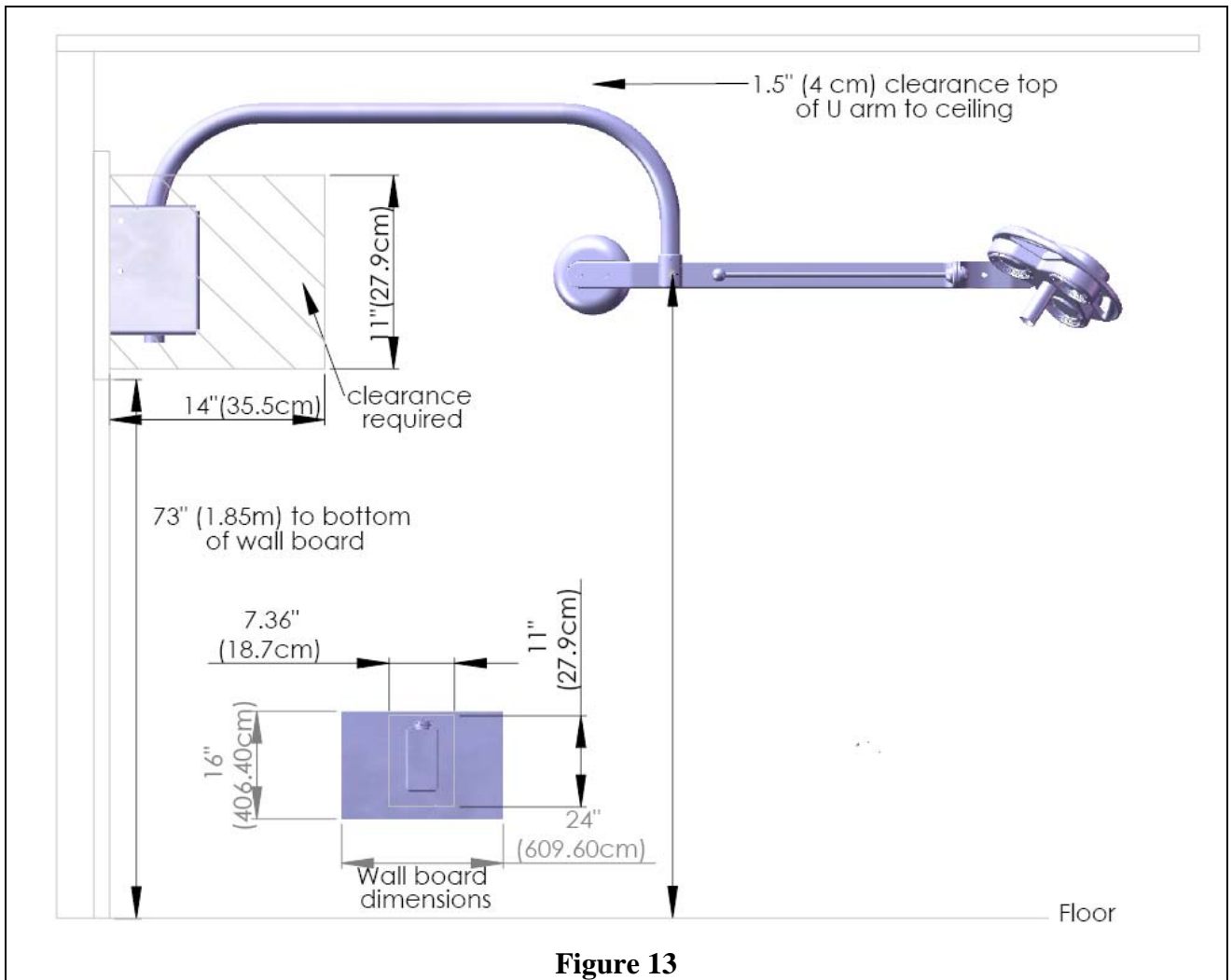
2. If using dual mount seismic bracket, securely fasten dual mount seismic bracket to a structural member in the ceiling. Three ½" (12mm) holes on a 12" (30.4cm) bolt circle have been provided on the flat plate of seismic bracket.
3. To install dome covers, position both halves of the dome and secure with the 4 plastic screws provided. (There is a nylon collar on ceiling arm just below the transformer box, adjust the collar by loosening the set screw on collar so it holds the dome covers).



**Figure 12**

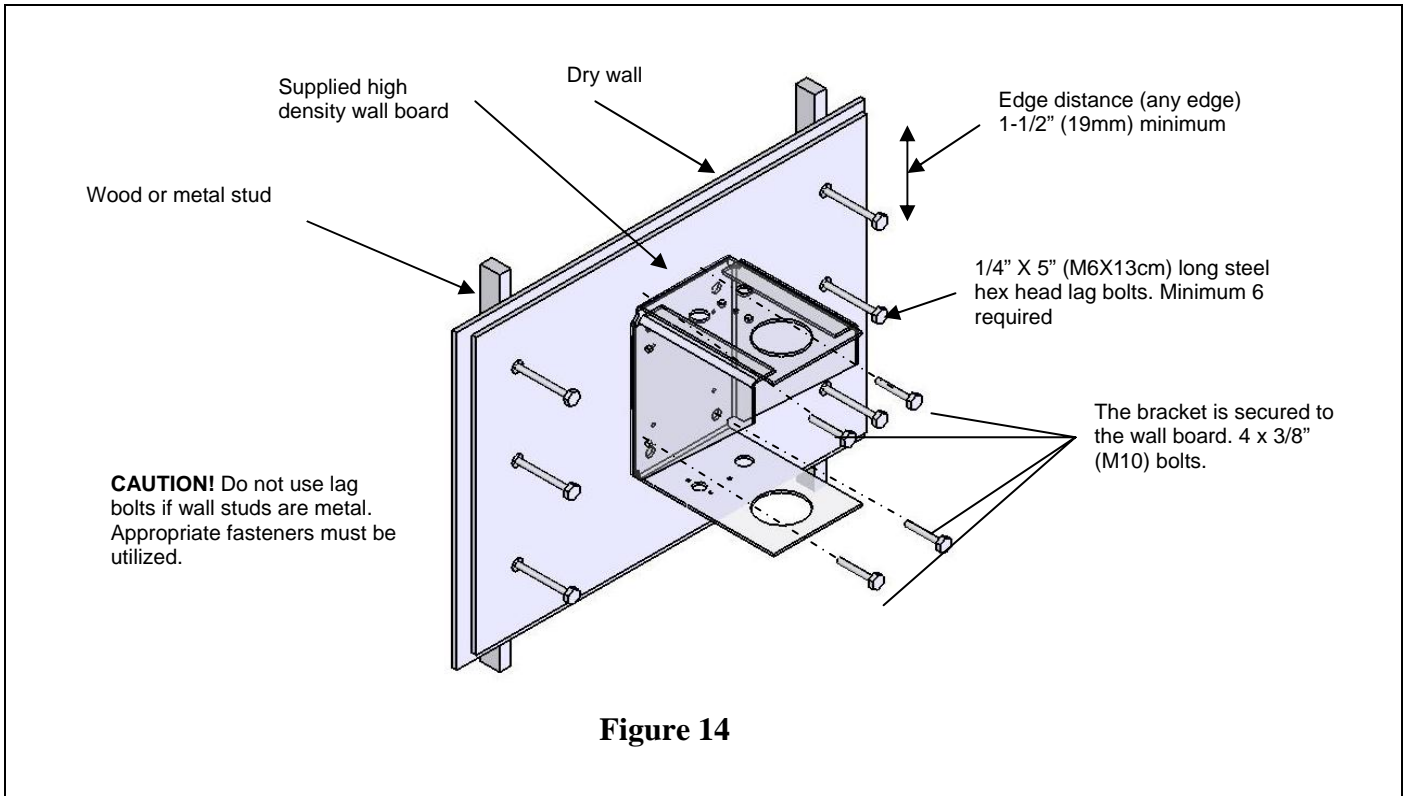
#### 5.5 Installation Instructions (Wall Light)

1. Locate the two wall studs or other permanent members to which the board is to be affixed.
2. For a room with a floor-to-ceiling distance of eight feet, mark the position of the wall board on the wall so the bottom of the wall bracket is 73" (1.85m) from the floor surface. This should place the Extension U-arm where it will move freely without scraping the ceiling. (This is based on the assumption that the floor-to-ceiling height is 8' (2.4m)).



**Figure 13**

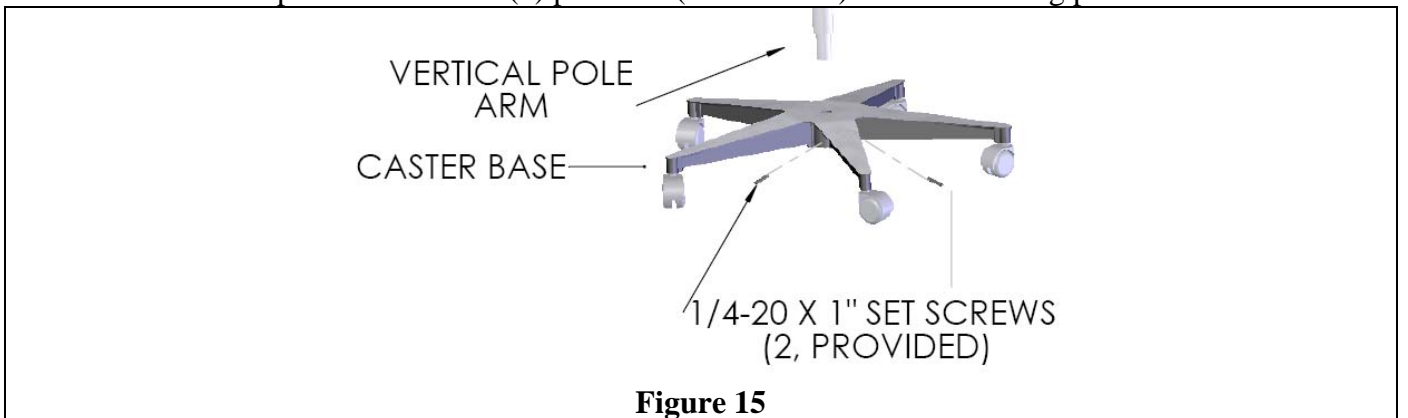
3. Measure and mark on the wall board two vertical lines for three lag bolts, right and left of the wall board. Drill three holes on each line, approximately the size of the lag bolts chosen for mounting.  
**RECOMMENDATION: LAG BOLTS OF AT LEAST 1/4" X 5" (M8 X 130mm) LONG, WITH WASHERS, SHOULD BE USED. BE SURE TO DRILL APPROPRIATE PILOT HOLES OF ADEQUATE DEPTH TO AVOID BREAKING THE BOLTS.**



4. Place the wall board in position and secure through the wall to the wooden wall studs, using six lag bolts. **CAUTION! EACH LAG BOLT MUST BE CAPABLE OF RESISTING PULL OUT AND SHEAR FORCES OF 100 POUNDS (45kg).**
5. Ensure the Extension U-arm is level.
6. Follow instructions in section 5.2 (Items 5 thru 9) to complete the balance arm assembly.

#### 5.6 Installation Instructions (Mobile Light)

1. Insert the bottom of the vertical pole arm into the center housing of the caster base. Secure the vertical pole with the two (2) provided (1/4-20 X 1") set screws using provided Allen wrench.



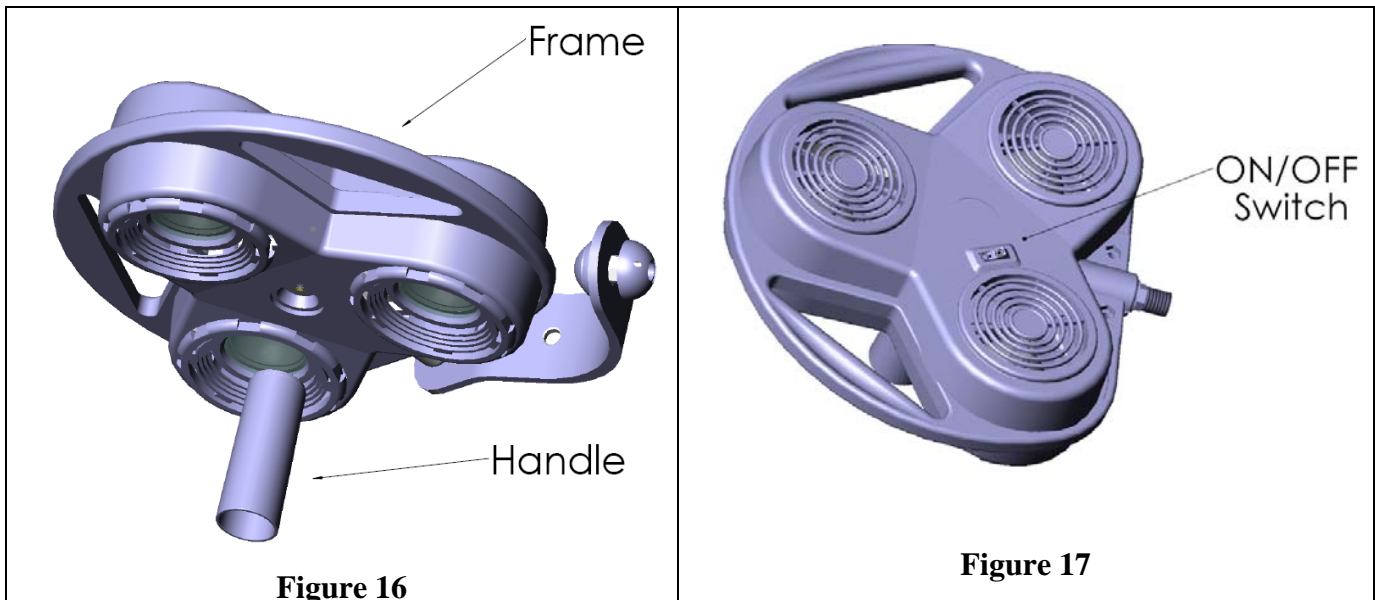
2. Follow instructions in section 5.2 (items 5 thru 9) to complete the light assembly.

## 6. Operating Instructions

1. After successful assembly of your light, plug the Hospital Grade plug into an appropriate Hospital Grade outlet. Do not use three-to-two prong adapters that are not grounded.
2. Turn on your light with the rocker switch in the back cover of the lamp head. (If a wall switch or dimmer is also in use, be sure to have the dimmer/switch in the off position prior to turning on the lamp.)



**CAUTION: IT IS NOT RECOMMENDED TO USE A WALL DIMMER WITH THE LIGHT. IF A WALL DIMMER MUST BE USED, ENSURE THAT THE LAMPHEAD SWITCH IS TURNED OFF BEFORE TURNING ON THE WALL DIMMER. FAILURE TO DO SO MAY RESULT IN POWER INTERRUPTION AND FUSE FAILURE.**



### RANGES OF MOTION (REFER TO FIGURE 18)

**EXTENSION ARM /BALANCE ARM MOVEMENT:** The balance arm moves 340 degrees both horizontally and vertically at its junction with the extension arm.

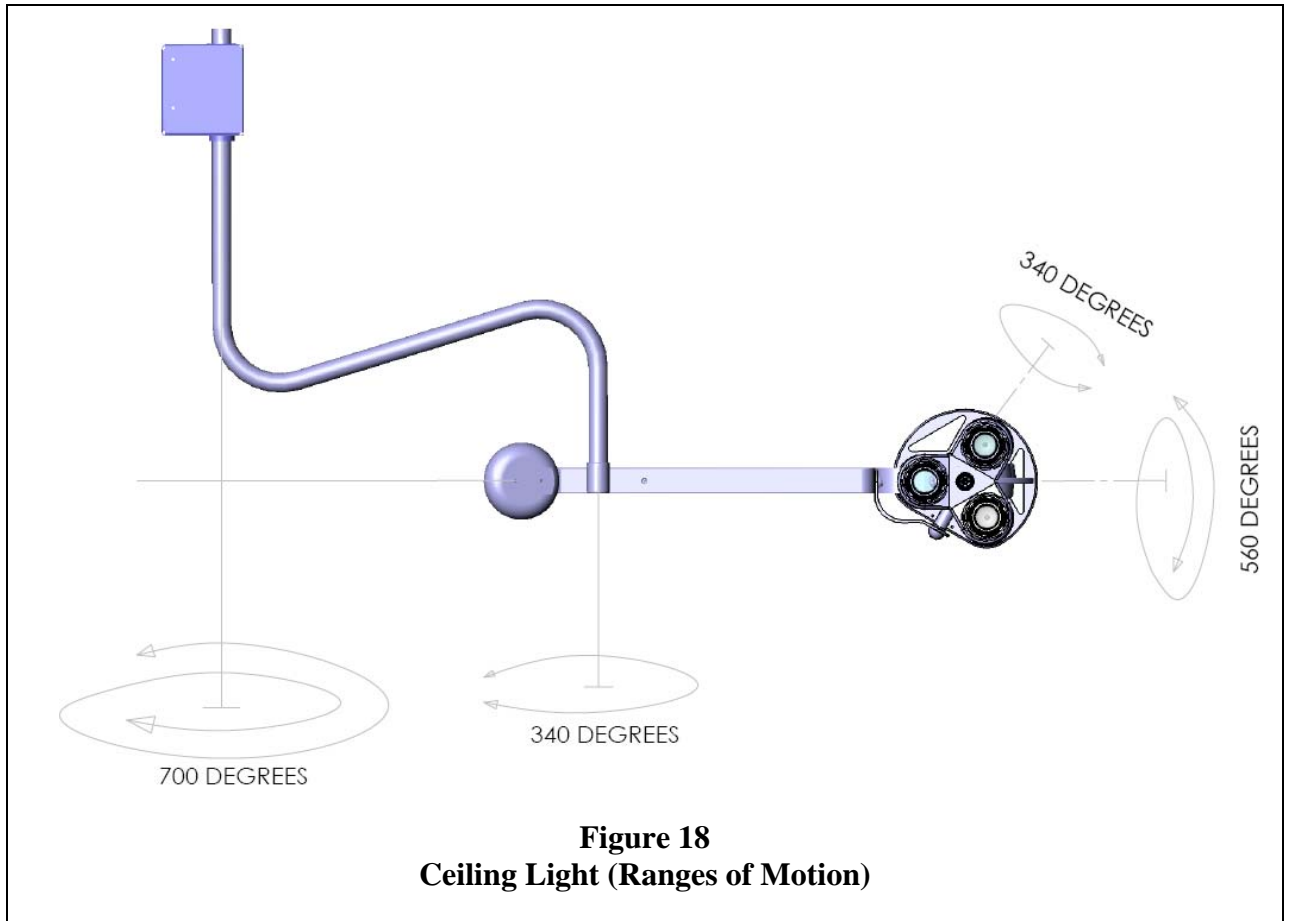
**LAMP HEAD/YOKE & YOKE/BALANCE ARM MOVEMENT:** The lamp head rotates 340 degrees at its connection to the yoke. The yoke rotates 560 degrees at its connection to the balance arm. The two co-act to provide unlimited choices for beam positioning. All axis of rotation have very little resistance and no force is needed or should be used to rotate the light.

**REACH:** With the lamp head/balance arm fully extended in the horizontal plane, the reach from the center of the ceiling “Z” extension arm to beam center is 58” (1.5m).

**CEILING EXTENSION ARM MOVEMENT:** The ceiling “Z” extension arm rotates 700 degrees. There is a built-in rotation stop which limits rotary movement in either direction.



**CAUTION! DO NOT FORCE MOVEMENT PAST ITS STOP POSITION.**



## 7. Maintenance

While your lamp light has been designed to provide you many hours of professional performance, it will benefit from your periodic care and concern.

### 7.1 Cleaning and Disinfection


- The covers and frame may easily be cleaned with a soft damp cloth of a mild soap water solution or mineral spirits.
- Isopropyl alcohol is another acceptable cleansing agent. The front glass filters can be cleaned with any commercial glass cleaner.
- The metal components are powder coated for long life and can be cleaned with a damp cloth of mild soap and water solution, mineral spirits or, isopropyl alcohol.
- Periodically dust the backside louvers to ensure uninterrupted convection of ambient air. This air movement also cools the three lamp/reflector assemblies, further extending their effectiveness and useful life.

### 7.2 Handle Autoclaving

- The Delrin handles may be sterilized as any stainless steel instruments.

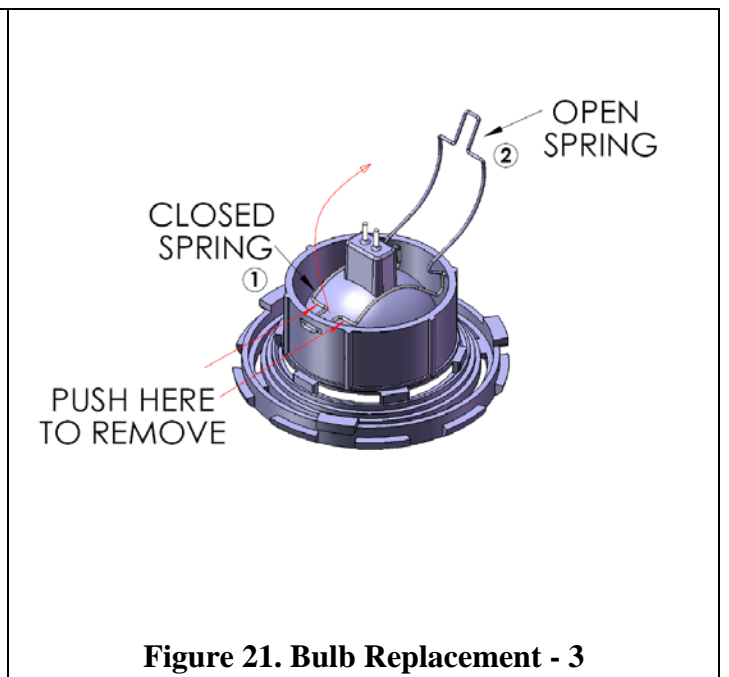
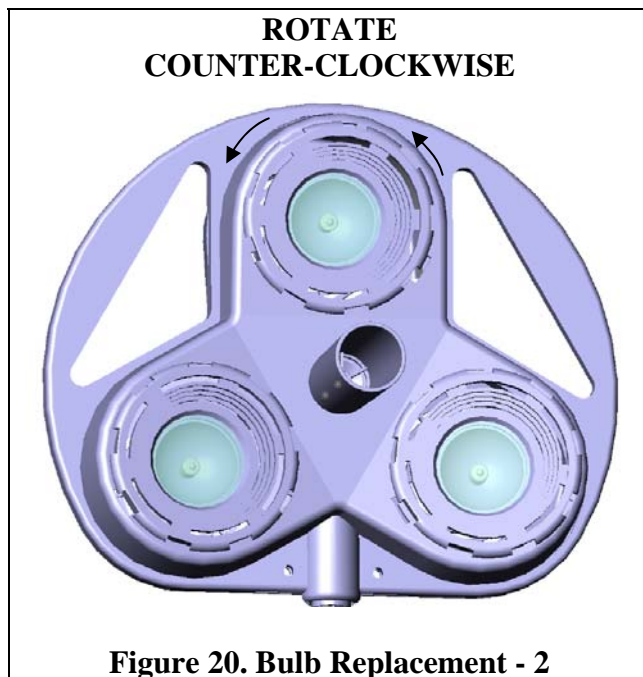
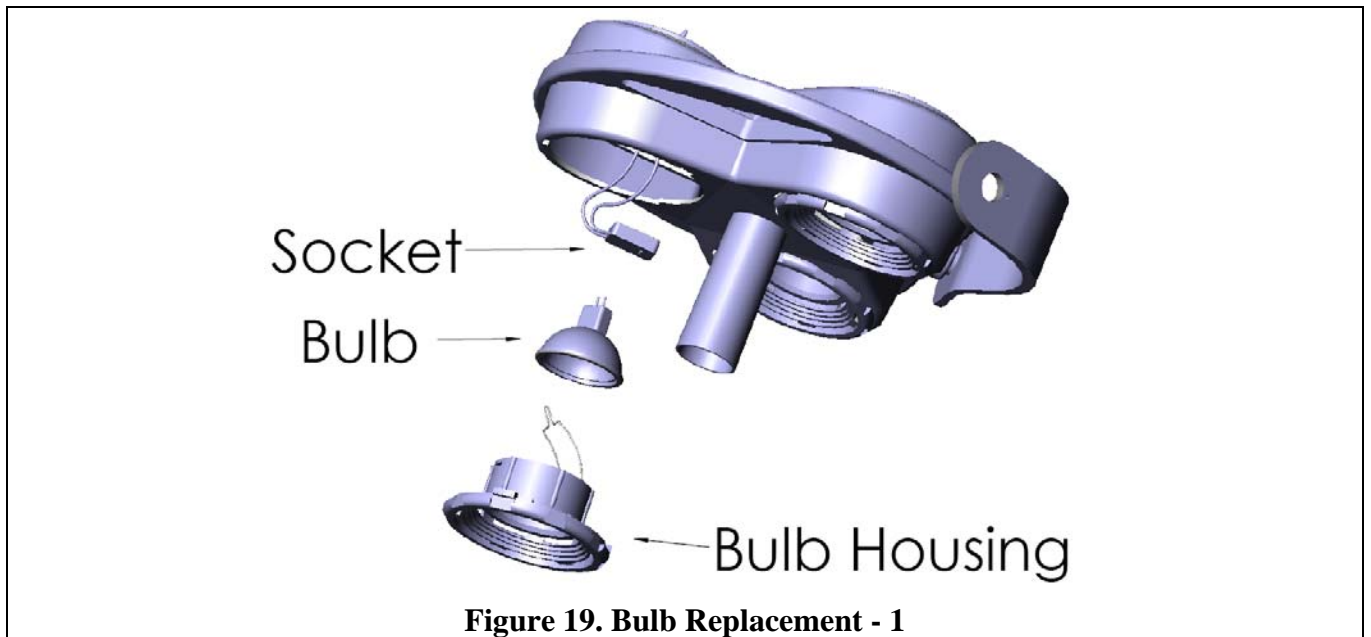
- Although it is of sufficient diameter to engage a disposable sleeve, it is recommended that it is treated as a stainless steel item when submitting it to sterilization process below:
  1. A flash cycle at 275 – 279<sup>o</sup>F (135 – 137<sup>o</sup>C), for 16 minutes
  2. A standard cycle at 275 – 279<sup>o</sup>F (135 – 137<sup>o</sup>C), for 4 minutes

### 7.3 Bulb Replacement

	<p><b>CAUTION: ONLY USE OSRAM/SYLVANIA TRU-AIM TITAN BULBS (DICHROIC, 12V/35W/10°), ANY DEVIATION FROM THESE INSTRUCTIONS MAY SERIOUSLY DAMAGE YOUR LIGHT. 35WATTS IS MAXIMUM ALLOWABLE.</b></p>
---	--

Should you experience a bulb failure, ALLOW SUFFICIENT TIME FOR IT TO COOL BEFORE ATTEMPTING A REPLACEMENT. Once cool, you should:

1. Refer to figures 19, 20 & 21. Turn the lamp head over so the three glass assemblies face upward.
2. With one hand supporting the backside of the lamp, grasp the notched ring assembly (1) and twist it counter clockwise.
3. Grasp the bulb with one hand and unplug socket connector with the other.
4. The notched ring assembly may now be removed from the lamp head and placed face down on a flat surface.
5. Hold the notched ring assembly with thumbs and place two index fingers at flat part of spring (two red lines in figure 21), pull the spring towards you pulling it out from the slot (keep other two ends of spring inside its holes).
6. Remove old bulb.
7. Install new bulb. Do not touch inside reflector surface of bulb, always grasp from bulb outside edges.
8. Close the retainer spring on the bulb by inserting the front tab of spring in the slot (using index fingers), so that it fits properly. Check to ensure proper seating of the spring, by pulling on the bulb. [Position (1) in figure 21 is “CLOSED SPRING”]. Ensure that two open ends of spring are properly seated into holes in the notched ring assembly.
9. Reconnect plug socket to bulb.
10. Replace the notched ring assembly in the lamp head by aligning the three guide projections into the slots on the lamp head. Refer to figure 20. Press gently inward as you twist the assembly clockwise. You will hit a stop and set in place. Before turning the lamp head over, BE POSITIVE THE ASSEMBLY IS PROPERLY SEATED by comparing it with the other two.
11. The light is now ready for use.



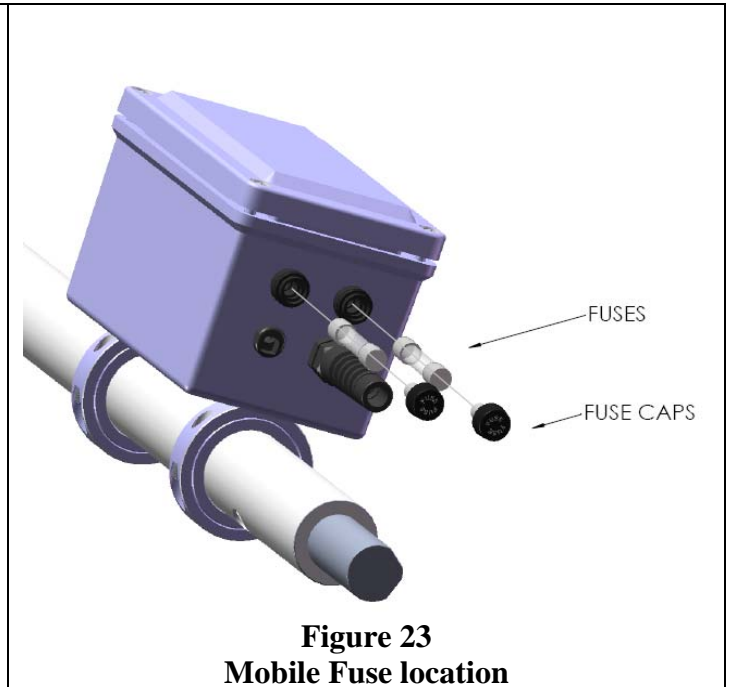
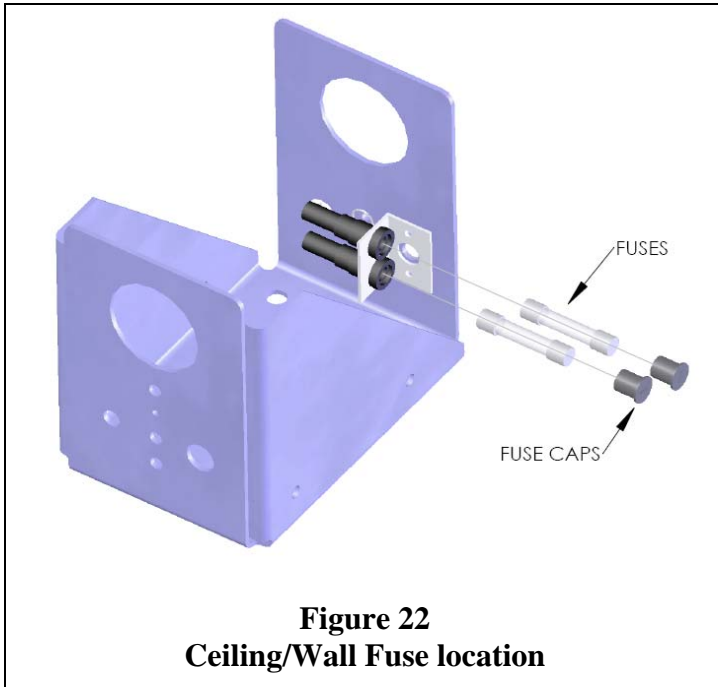
#### 7.4 Fuse Replacement

1. Refer to figures 22 & 23. Remove the plug from outlet.
2. Locate two fuse blocks.
  - Ceiling and Wall Models:** Unscrew the plastic screws from transformer cover. Take off the transformer cover. Locate fuse holders (2) inside the transformer housing.
  - Mobile Models:** Locate two fuse blocks on the bottom of the transformer housing.
3. Push in and turn the fuse holder counter clockwise. Remove the fuse holder from the fuse block.
4. Remove and replace the fuse. A blown fuse may not be noticeably different from a good one. **BOTH FUSES SHOULD BE REPLACED AT THE SAME TIME.**
5. Follow procedure in reverse to return lamp to operating condition.
6. Fuse Replacement Specifications:
  - a. USA : Sunnex part# 18565 (2 AMP, 250V, 1/4" X 1-1/4")

MUST USE A SLOW-BLOW FUSE

- b. Europe: Sunnex part# 18641 (1.25 AMP, 250V, 5mm X 20mm)

MUST USE A SLOW-BLOW FUSE



## 8. Warranty

### 8.1 Limited Warranty.

Sunnex warrants that the Product, if properly used, will be free from defects in material and workmanship, for a period of three (3) years from the date of shipment to Customer. This Limited Warranty extends only to the original buyer. If the Product is determined to be defective within the warranty period, Sunnex, at its option, will repair or replace the Product, at no charge or refund the then-current value of the Product.

### 8.2 Disclaimers and Limitations.

This Limited Warranty shall be the sole remedy of Customer and the sole liability of Sunnex to Customer.

This Limited Warranty does not extend or apply to any defects, failures or damage due to or resulting from: (a) acts of God, accident, misuse, use of the Product other than its normal and customary manner, abuse or negligence; (b) everyday wear and tear; (c) alteration or modification of, or to any part of, the Product; (d) improper operation and maintenance; or (d) any repairs or attempted repairs by anyone other than Sunnex. This Limited Warranty does not cover any products sold AS IS or WITH ALL FAULTS. This Limited Warranty excludes the replacement of bulbs for the Product.

TO THE FULL EXTENT PERMITTED BY APPLICABLE LAW, THIS LIMITED WARRANTY REPLACES ALL OTHER WARRANTIES OR CONDITIONS, EXPRESS OR IMPLIED INCLUDING, WITHOUT LIMITATION, ANY AND ALL IMPLIED WARRANTIES OF MERCHANTABILITY AND FITNESS FOR A PARTICULAR PURPOSE. SUNNEX DISCLAIMS ALL OTHER WARRANTIES AND CONDITIONS, EXPRESS OR IMPLIED, INCLUDING, WITHOUT LIMITATION, IMPLIED WARRANTIES OF TITLE, NONINFRINGEMENT, ABSENCE OF LIENS OR INCUMBRANCES,

MERCHANTABILITY AND FITNESS FOR A PARTICULAR PURPOSE, REGARDLESS OF WHETHER SUNNEX KNOWS OR HAS REASON TO KNOW OF CUSTOMER'S PARTICULAR NEEDS. IF IMPLIED WARRANTIES MAY NOT BE DISCLAIMED UNDER APPLICABLE LAW, THEN ANY IMPLIED WARRANTIES THAT MAY BE IMPOSED BY LAW ARE LIMITED IN DURATION TO THE LIMITED WARRANTY PERIOD SET FORTH HEREIN, AND THEREAFTER ANY IMPLIED WARRANTIES ARE EXPRESSLY DISCLAIMED.

No employee, agent, dealer, reseller or distributor of Sunnex is authorized to modify this Limited Warranty, or to make any additional warranties.

REPAIR, REPLACEMENT OR REFUND, AS PROVIDED UNDER THIS LIMITED WARRANTY, ARE CUSTOMER'S SOLE AND EXCLUSIVE REMEDIES. IN NO EVENT SHALL SUNNEX BE LIABLE FOR ANY DIRECT, INDIRECT, SPECIAL, INCIDENTAL, CONSEQUENTIAL OR TORT DAMAGES OR LOSSES, WHETHER TO PERSON OR PROPERTY, INCLUDING DEATH, ARISING OUT OF OR RESULTING FROM ANY BREACH OF WARRANTY OR ANY OTHER LEGAL THEORY, OR ARISING OUT OF OR IN CONNECTION WITH THE PRODUCT OR CUSTOMER'S USE OF THE PRODUCT, EVEN IF SUNNEX IS ADVISED OF THE POSSIBILITY OF SUCH DAMAGES. IN ANY EVENT, THE TOTAL LIABILITY OF SUNNEX TO YOU FOR ANY CAUSE WHATSOEVER SHALL BE LIMITED TO THE PURCHASE PRICE YOU PAID FOR THE PRODUCT. THIS LIMITATION SHALL APPLY REGARDLESS OF THE FORM OF ACTION, WHETHER IN CONTRACT OR TORT (INCLUDING, WITHOUT LIMITATION, NEGLIGENCE).

SOME STATES DO NOT ALLOW THE EXCLUSION OR LIMITATION OF INCIDENTAL OR CONSEQUENTIAL DAMAGES, OR ALLOW LIMITATIONS ON HOW LONG AN IMPLIED WARRANTY LASTS, SO THE ABOVE LIMITATIONS OR EXCLUSIONS MAY NOT APPLY TO YOU. THIS LIMITED WARRANTY GIVES YOU SPECIFIC LEGAL RIGHTS, AND YOU MAY ALSO HAVE OTHER RIGHTS THAT VARY FROM STATE TO STATE.

### 8.3 Claims Procedure.

(a) Customer must contact Sunnex at (800)-445-7869 with a request for warranty service or to report a technical issue. Sunnex Technical Support will attempt to identify, diagnose and resolve the reported problem via the telephone.

(b) If attempts by Sunnex to resolve a reported problem are unsuccessful, Customer will then be provided with a Customer-specific Returned Merchandise Authorization number ("RMA"). The RMA number must be noted on any correspondence to Sunnex and displayed prominently on the outside packaging of any Product shipped to Sunnex.

(c) Within ten (10) days of receipt of the RMA number, Customer must ship the Product to Sunnex at Customer's expense (insuring the Product is recommended) in either its original packaging or packaging affording an equal degree of protection, to *Sunnex Inc. 3 Huron Drive, Natick MA 01760*, with a statement describing the problem in reasonable specificity. Proof of purchase must be included to obtain warranty service. Sunnex will not be held responsible for shipping damages that occur in transit. Any damage to the Product during shipping will not be covered under this Limited Warranty and shall be subject to a service charge.

(d) Subject to the limitations specified herein, upon receipt, Sunnex will inspect the shipped Product and, at its sole discretion, repair or replace the Product with the same or a like product to the extent it does not conform to this Limited Warranty. In the event Sunnex, at its sole discretion, opts to replace the Product, should said product be discontinued or no longer be offered for sale by Sunnex, a like product in design and functionality will be provided to Customer.

(e) Sunnex will ship the repaired Product or a replacement to Customer within ten (10) business days after receipt from the date that Sunnex receives the Product. Standard shipments to the Customer will be paid by Sunnex. Sunnex assumes no responsibility for shipment delays by the carrier.

(f) If Customer requires warranty service to be provided in less than ten (10) business days, but not less than three (3) business days, Sunnex will charge Customer an additional One Hundred Dollars (\$100.00) express handling charge per request for each Product.

#### 8.4 Customer Responsibilities.

(a) To validated warranty customer is required to fill out online or provided warranty card.

(b) Customer is required to follow the user manual associated with the Product for proper operation.

(c) Customer is required to perform periodic preventive maintenance as called for in the user manual associated with the Product.

(d) Any modifications or repairs made to the Product without prior written authorization from Sunnex will render this Limited Warranty null and void. Instances whereby this is determined to be the case by Sunnex technical staff will be subject to an initial service charge of \$75.00 (\$25.00 evaluation charge and \$50.00 minimum labor cost).

#### 8.5 Miscellaneous.

In the event that any provision of this Limited Warranty should be or becomes invalid and/or unenforceable during the warranty period, the remaining provisions shall continue in full force and effect.

The provisions of this Limited Warranty shall be governed by the laws of the Commonwealth of Massachusetts without regard to its conflict of laws principles. This Limited Warranty shall not be modified except by an agreement signed by both parties specifically referencing this Limited Warranty.

This Limited Warranty represents the entire agreement between Sunnex and Customer with respect to the subject matter herein and supersedes all prior or contemporaneous oral or written communications, representations, understandings or agreements relating to this subject.

For service assistance or resolution of a service problem, or for Product or warranty information, write to *Sunnex Inc. 3 Huron Drive, Natick MA 01760*, or visit [www.sunnex.com](http://www.sunnex.com).

#### 8.6 Optional Extended Limited Warranty Plan.

The purchase of the Optional Extended Limited Warranty extends the duration of this Limited Warranty from a period of three (3) years to a period of five (5) years from the date of shipment to Customer. The Optional Limited Warranty may be purchased at the time of the original purchase of the Product or the Extended Limited Warranty to become effective and apply to the Product. Customer must pay the appropriate Extended Limited Warranty fee and upon initial purchase, register each Product with Sunnex within thirty (30) days from the date of shipment to Customer by Sunnex, or a Sunnex authorized dealer or reseller.

#### **Sunnex Customer Service**

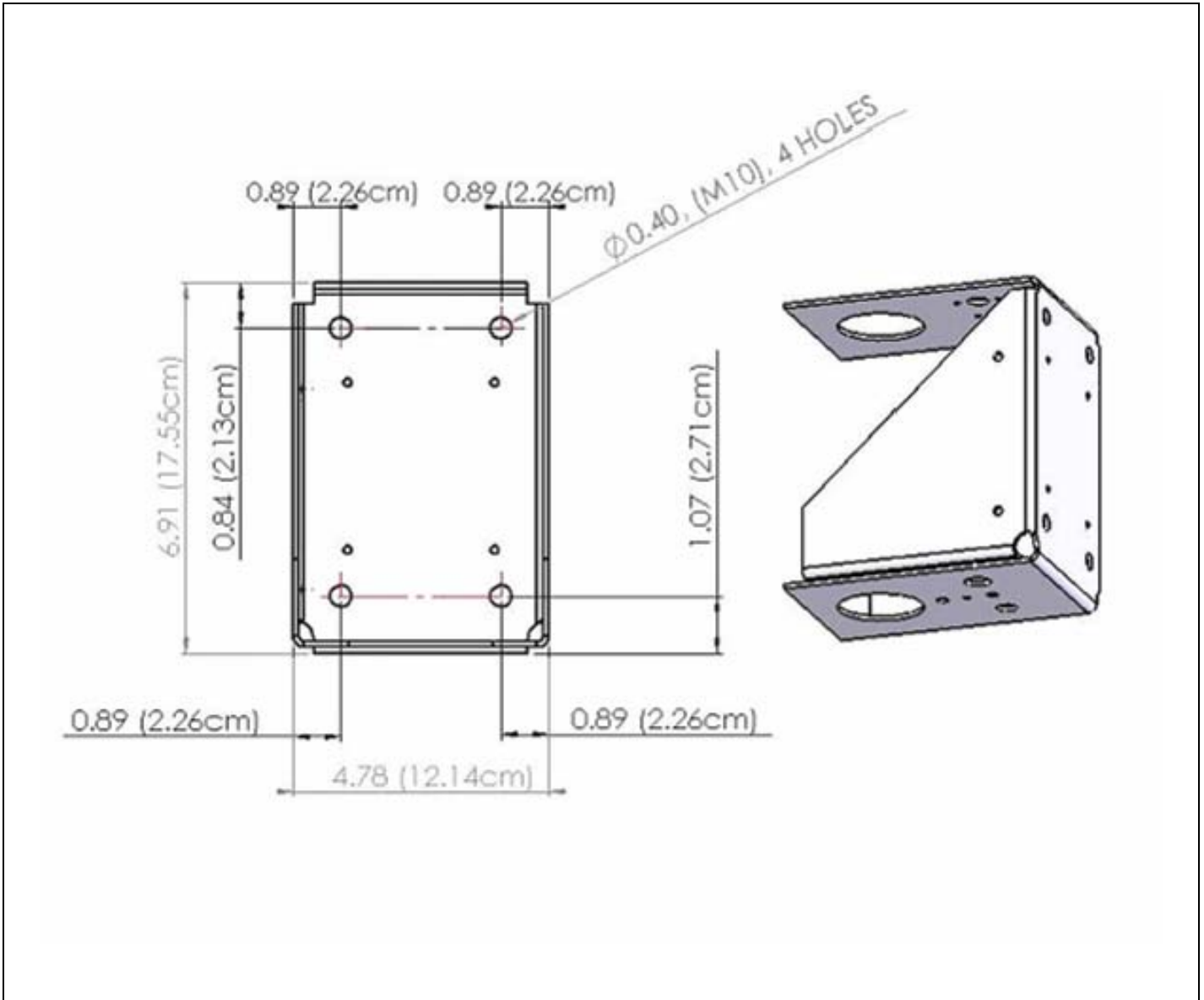
Sunnex Inc, USA	+ 1 508 651 0009
Sunnex Equipment AB Sweden	+ 46 565 177 00
Warranty	+ 1 508 651 0009

## 9. Troubleshooting

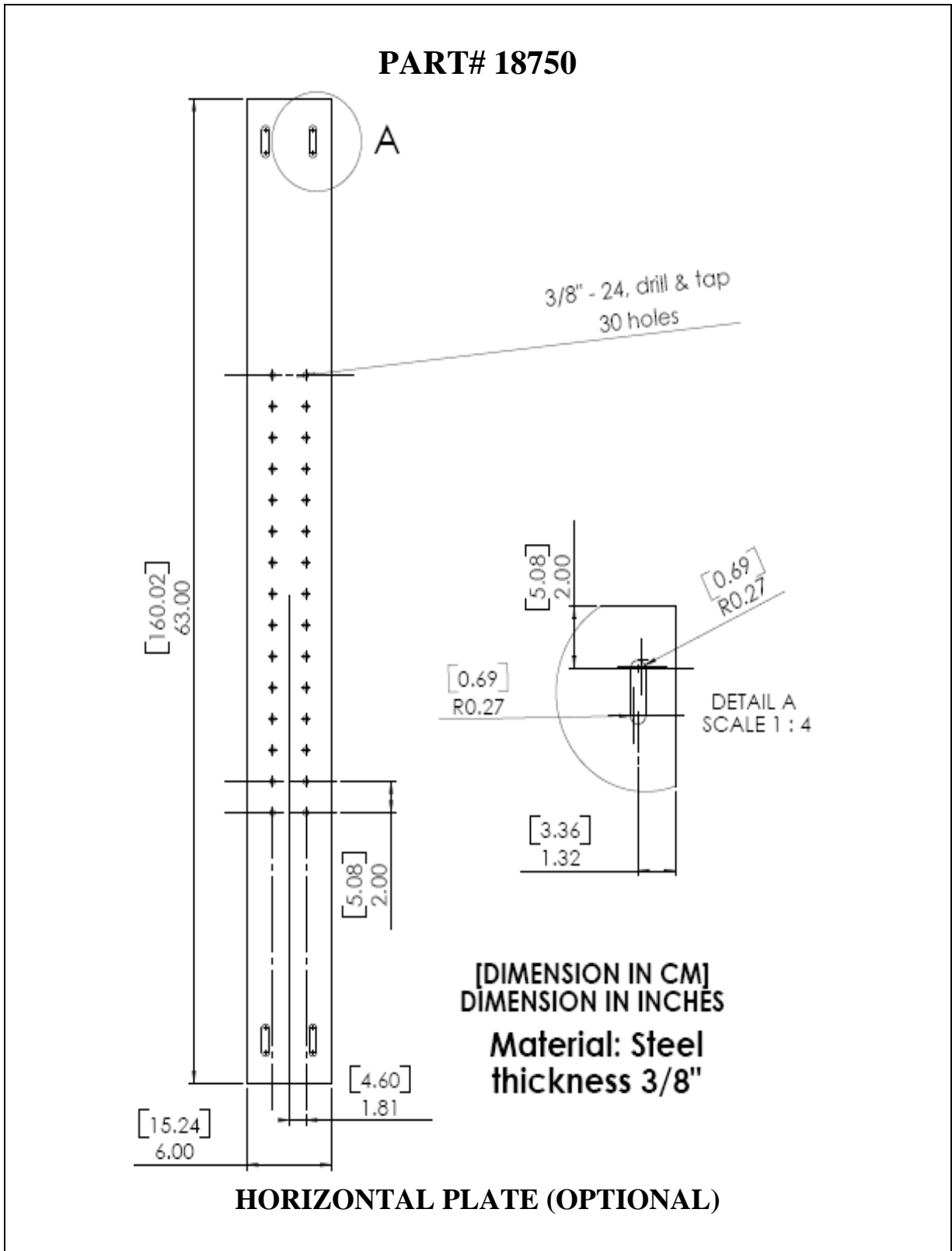
PROBLEM	POSSIBLE CAUSE	SOLUTION
No light from light head	Light head switch is on OFF position	Turn on the ON/OFF switch to ON position
No light from light head, when ON/OFF switch is ON	Connection at balance arm and extension arm not correct	Check the connection
	Bulb has not been installed or it has burned out	Refer to bulb replacement procedure in the manual
	Fuse is blown	Replace BOTH FUSES following the fuse replacement procedure
	No power to the transformer box	Check for facility power to the transformer box
	Transformer is malfunctioning	Check for 14 V AC output at the transformer when it is under load
	Incorrect bulb installed	Install correct bulb
Bulb burns out quickly	Incorrect bulb installed in the light head	Install correct bulb
Light output is irregular in its shape or intensity	Incorrect bulb installed in the light head	Install correct bulb
	Bulb/reflector is not seated in its holder correctly	Adjust the bulb/reflector so it seats in the holder properly
No light from light head even when the bulb and fuse are in good condition, light head flashes intermittently when light head or arms are moved	Circuit or wiring problem within transformer, arm assemblies or other part of lighting system	Check all wiring connections. If problem cannot be repaired, call Customer Service
Head & balance arm drift (moves down) slightly	Normal wear in leather anti-squeak washer	GENTLY tighten balance arm nut
Extension arm does not rotate freely or drifts (Ceiling)	Improper installation of the ceiling bracket	Check for excessive flexing of ceiling support structure and check if ceiling plate is level. Readjust if necessary.
Extension arm does not rotate freely or drifts (Wall)	Improper installation of the wall board on wall studs of the room	Check the joint of transformer housing with wall board, and wall board with wall studs. Readjust if necessary.
Balance arm does not rotate freely or drifts when released in desired position	The nut joining the balance arm and the extension arm is loose	Tighten this nut slightly
Light head does not rotate freely at lamp head/yoke joint	The screw/nut joining lamp head with the yoke is too tight or too loose	Tighten/loosen as appropriate until free movement of lamp head is achieved

10. Appendix

**Appendix A: TRANSFORMER HOUSING (CEILING, DUAL & WALL)  
DIMENSIONS**

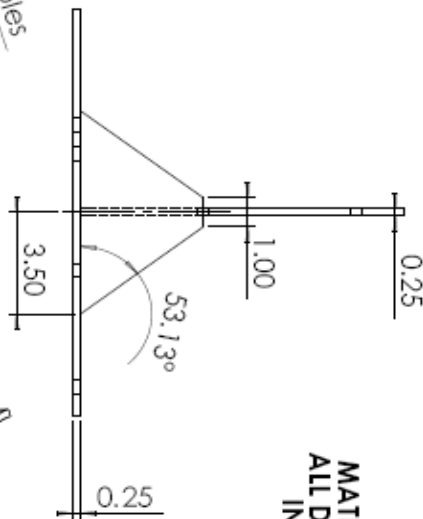
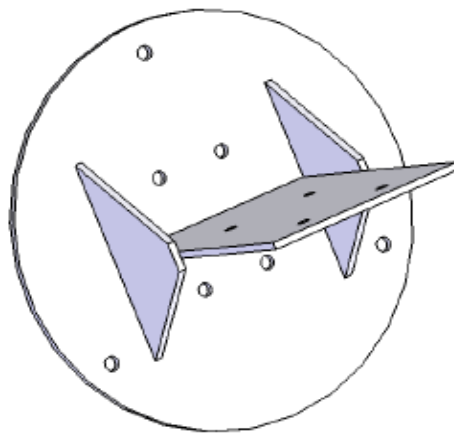
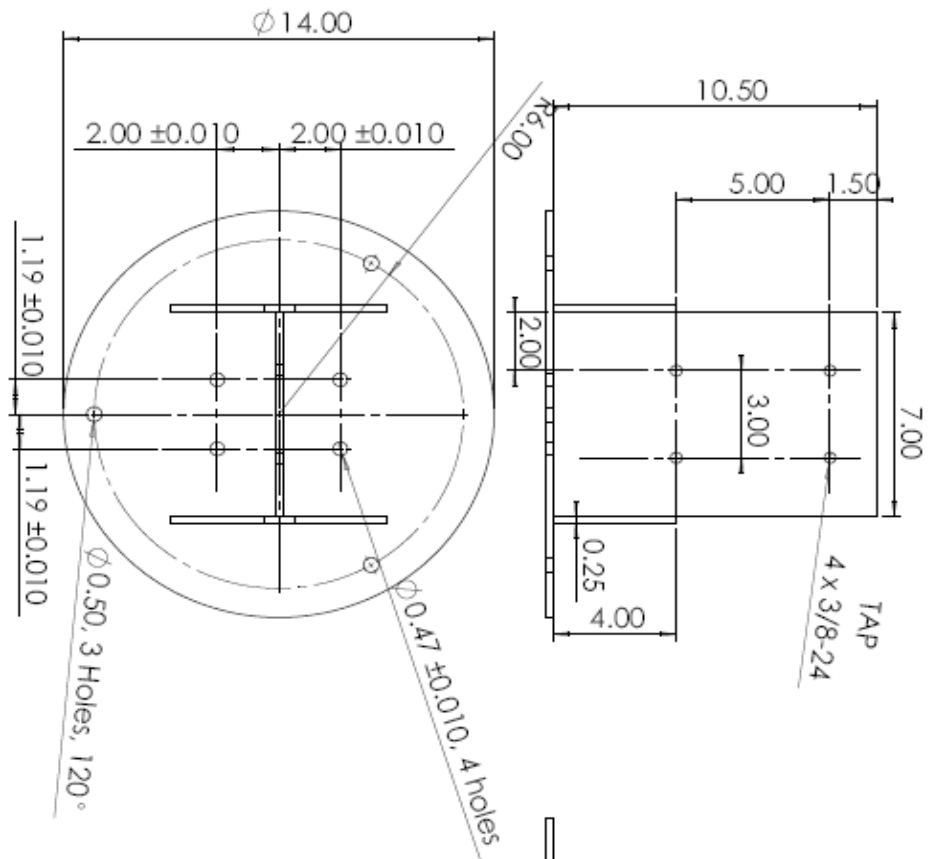


# Appendix B: OPTIONAL STEEL STRUCTURE



# APPENDIX C: DUAL MOUNT SEISMIC BRACKET

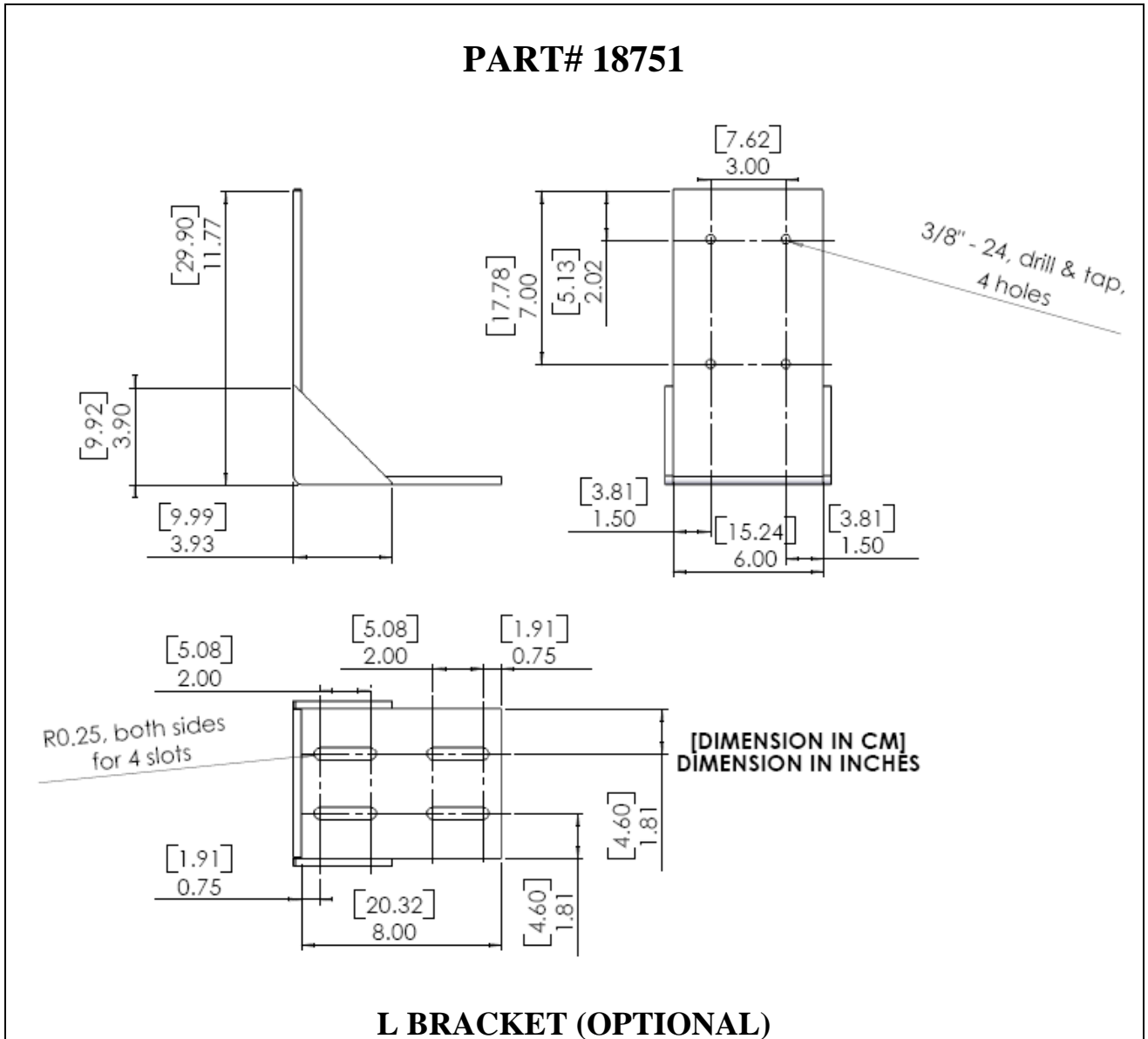
## PART# 18523



MATERIAL: STEEL  
ALL DIMENSIONS  
IN INCHES

### SEISMIC BRACKET (OPTIONAL)

# APPENDIX D: OPTIONAL STEEL STRUCTURE



# WWW.SUNNEXMEDICAL.COM



**Sunnex is certified  
ISO 9001:2000 by**



---

Sunnex, Inc.  
3 Huron Drive  
Natick, MA 01760-1314  
USA  
Tel: + 1 800 445 7869  
Fax: 1 508 651 0099  
Email: sales@sunnex.com

Sunnex Equipment AB  
Box 8064  
SE-163 08 Spånga  
Sweden  
Tel: + 46 8 546 802 30  
Fax: + 46 8 546 802 59  
Email: info@sunnex.se

Sunnex Equipment Sarl  
ZI. Les Milles B.P. 154 000  
13794 Aix en Provence, Cedex 3  
France  
Tel: + 33 442 39 78 96  
Fax: + 33 442 39 78 77  
Email: sunnex@sunnex.fr

Sunnex GmbH  
Ricarda-Huch-Str. 2  
D-14480 Potsdam  
Germany  
Tel: + 49 331 600 77 27  
Fax: + 49 331 600 77 63  
Email: info@sunnex.de

REVISION 3.0  
NOVEMBER 2007